

Operation and Service Manual

# Quad Digital Voltmeter

---

**SIM970**



Stanford Research Systems

---

Revision 1.19 • May 28, 2010

---

## Certification

Stanford Research Systems certifies that this product met its published specifications at the time of shipment.

## Warranty

This Stanford Research Systems product is warranted against defects in materials and workmanship for a period of one (1) year from the date of shipment.

## Service

For warranty service or repair, this product must be returned to a Stanford Research Systems authorized service facility. Contact Stanford Research Systems or an authorized representative before returning this product for repair.

Information in this document is subject to change without notice.

Copyright © Stanford Research Systems, Inc., 2003 – 2010. All rights reserved.

Stanford Research Systems, Inc.  
1290–D Reamwood Avenue  
Sunnyvale, CA 94089 USA  
Phone: (408) 744-9040 • Fax: (408) 744-9049  
**www.thinkSRS.com • e-mail: info@thinkSRS.com**

Printed in U.S.A.

Document number 9-01559-903



*SIM970 Quad Digital Voltmeter*

---

# Contents

---

<b>General Information</b>	<b>iii</b>
Safety and Preparation for Use . . . . .	iii
Symbols . . . . .	iv
Notation . . . . .	v
Specifications . . . . .	vi
<b>1 Getting Started</b>	<b>1 – 1</b>
1.1 Introduction to the Instrument . . . . .	1–2
1.2 Front-Panel Operation . . . . .	1–3
1.3 Input Protection . . . . .	1–4
1.4 Power-On . . . . .	1–5
1.5 Restoring the Default Configuration . . . . .	1–6
1.6 SIM Interface . . . . .	1–7
<b>2 Description of Operation</b>	<b>2 – 1</b>
2.1 Operating Modes . . . . .	2–2
2.2 Autoranging . . . . .	2–8
2.3 Controlling the Mode and Auto Settings . . . . .	2–9
2.4 Other Instrument Features . . . . .	2–10
2.5 Triggering . . . . .	2–10
<b>3 Remote Operation</b>	<b>3 – 1</b>
3.1 Index of Common Commands . . . . .	3–2
3.2 Alphabetic List of Commands . . . . .	3–4
3.3 Introduction . . . . .	3–6
3.4 Commands . . . . .	3–6
3.5 Status Model . . . . .	3–18



---

## General Information

---

The SIM970 Quad Digital Voltmeter, part of Stanford Research Systems' Small Instrumentation Modules family, consists of four isolated digital voltmeter (DVM) channels. Five and a half digits of resolution and overall accuracy are available for inputs within  $\pm 20$  volts.

## Safety and Preparation for Use



### WARNING

The front-panel inputs to the SIM970 are isolated from the Earth, the power-line-outlet ground, the metal chassis of the module, and from each other. No dangerous voltages are generated by the module. However, if a dangerous voltage is applied to an input, it may be present on the outer casing of the input coaxial (BNC) connector, and may cause injury or death.

*Do not exceed  $\pm 20$  volts to the Earth at the positive (center) terminal of each input connector. Do not exceed  $\pm 20$  volts to the Earth at the negative (shield) terminal of each input connector.*

Do not install substitute parts or perform unauthorized modifications to this instrument.

The SIM970 is a double-wide module designed to be used inside the SIM900 Mainframe. Do not turn on the power to the mainframe or apply voltage inputs to the module until the module is completely inserted into the mainframe and locked in place.

### Symbols you may Find on SRS Products

Symbol	Description
	Alternating current
	Caution - risk of electric shock
	Frame or chassis terminal
	Caution - refer to accompanying documents
	Earth (ground) terminal
	Battery
	Fuse
	On (supply)
	Off (supply)

## Notation

The following notation will be used throughout this manual:



### WARNING

A warning means that injury or death is possible if the instructions are not obeyed.



### CAUTION

A caution means that damage to the instrument or other equipment is possible.

- Front-panel buttons are set as [Button];  
[Adjust ▲▼] is shorthand for “[Adjust ▲] & [Adjust ▼]”.
- Front-panel indicators are set as *Overload*.
- Signal names are set as BUSY.
- Signal levels are set as HIGH.
- Remote command names are set as \*IDN?.
- Literal text other than command names is set as OFF.
- Special ASCII characters are set as <CR>.

## Specifications

### Ranges, Resolution, and Noise

Under front-panel operation, the SIM970 has four voltage ranges. See Table 2.1 for more details.

Range	Maximum input voltage	Resolution [1]	Noise, counts rms [2, 3]
1	$\pm 19.9999$ V	100 $\mu$ V	1.5
2	$\pm 1.99999$ V	10 $\mu$ V	0.8
3	$\pm 999.99$ mV	10 $\mu$ V	0.8
4	$\pm 199.999$ mV	1 $\mu$ V	1.0

Conditions:

- [1] 7 1/2 digits, or 24 bits, of resolution are available through the remote interface.
- [2] One count is a unit change in the least-significant digit. Each front-panel display of the SIM970 has a capacity of  $\pm 199999$  counts.
- [3] Measured over 360 consecutive readings.

### Accuracy

Accuracy specifications [4, 5] are the same for all four channels. The four channels have isolated circuitry, so no channel-matching specifications exist.

In  $\pm(\text{reading} \times 10^{-6} + \text{counts})$  [2]

Range	24 hours, (23 $\pm$ 1) °C	90 days, (23 $\pm$ 5) °C	1 year, (23 $\pm$ 5) °C
1	10 + 2	50 + 2	80 + 2
2	2 + 2	50 + 2	80 + 2
3	2 + 2	50 + 2	80 + 2
4	2 + 4	50 + 6	80 + 6

(Relative to calibration standards [7])

Transfer accuracy: (24-hour count error)/2 (typ.) [6]

Conditions:

- [4] Inside a fully occupied SIM900 Mainframe; following a 2-hour warmup.
- [5] Specifications apply to Ranges 1 through 4 only, locally triggered (Table 2.1).
- [6] Within 10 minutes and  $\pm 0.5$  °C, within  $\pm 10\%$  of the initial value, on a fixed range, input voltage between 10% and 100% of the maximum for the range.
- [7] The absolute accuracy of the SRS factory calibration standard with respect to the United States NIST is  $6 \times 10^{-6}$  of the reading.



## Measuring Characteristics

		Min	Typ	Max	Units
Autoranging limits	Range 1	1.90000			V
	Range 2	.95000		1.99999	V
	Range 3	190.00		999.99	mV
	Range 4			199.999	mV
Input	Resistance [8]	9.9	10.0	10.1	MΩ
		3			GΩ
	Bias current [9]			1	pA
	Terminals	Isolated BNC [10]			
	Protection, center to shield	±60			V
	Protection, shield to Earth	±200			V
Trigger	Source	Local, external, or remote			
	External input	Rear BNC; TTL; active LOW			
	Latency		480		μs
	BUSY output	Rear BNC; TTL; active HIGH			
	BUSY impedance		50		Ω
Measurement	Method	24-bit, Delta-Sigma A/D converter			
	A/D linearity	Corrected by firmware [11]			
	Normal-mode rejection [12]	90			dB
	Common-mode rejection, DC [13]		125		dB
Output	Update frequency, 50 Hz FPLC [5]		3.0		Hz
	Update frequency, 60 Hz FPLC [5]		3.6		Hz
	Settling time, Ranges 1–3 [5, 14]			1	s
	Settling time, Range 4 [5, 14]		10		s
Operating	Displays	Red numeric LED, 0.30"			
		Green LED, range and autorange			
	Temperature [15]	0		40	°C
	Power		+5		V DC
	Supply current		480		mA

## Conditions:

- [8] Input resistance is 10 MΩ for Ranges 1 through 4. Operating modes with > 3 GΩ input resistance exist (Table 2.1).
- [9] At 23°C.
- [10] Amphenol 31–10–4052 or similar.
- [11] Included in the accuracy specifications.
- [12] At power-line frequency (FPLC): 59 Hz to 61 Hz or 49 Hz to 51 Hz.
- [13] For 1 kΩ unbalance in the shield.
- [14] To within 3 counts of the final reading, on a fixed range, for an input voltage step of 50% of the maximum voltage for the range, for 0 Ω source impedance.
- [15] Non-condensing.

**General Characteristics**

Number of channels	4
Interface	Serial (RS-232) through SIM interface
Connectors	BNC (4 front [10], 2 rear); DB-15 (male) SIM interface
Weight	2.3 lbs
Dimensions	3.0" W × 3.6" H × 7.0" D

---

# 1 Getting Started

---

This chapter gives you the necessary information to get started quickly with your SIM970 Quad Digital Voltmeter.

## In This Chapter

<b>1.1</b>	<b>Introduction to the Instrument</b> . . . . .	<b>1-2</b>
1.1.1	Front panel . . . . .	1-2
1.1.2	Rear panel . . . . .	1-3
<b>1.2</b>	<b>Front-Panel Operation</b> . . . . .	<b>1-3</b>
<b>1.3</b>	<b>Input Protection</b> . . . . .	<b>1-4</b>
<b>1.4</b>	<b>Power-On</b> . . . . .	<b>1-5</b>
<b>1.5</b>	<b>Restoring the Default Configuration</b> . . . . .	<b>1-6</b>
<b>1.6</b>	<b>SIM Interface</b> . . . . .	<b>1-7</b>
1.6.1	SIM interface connector . . . . .	1-7
1.6.2	Direct interfacing . . . . .	1-7

## 1.1 Introduction to the Instrument

chassis ground The SIM970 Quad Digital Voltmeter is designed to make precision low-frequency voltage measurements with excellent long-term accuracy. The four channels are galvanically isolated from one another and from the Earth (chassis ground). Autocalibration is performed with every reading by sequentially measuring not only the input voltage, but also the ground voltage and a fixed mid-scale voltage against a calibrated internal reference. This autocalibration routine virtually eliminates offsets and scale errors.

remote interface Computer access through the SIM900 Mainframe (RS-232 or GPIB) permits input voltage logging with 24 bits of resolution. This remote interface allows the user to exercise detailed control over the instrument's settings.

An external trigger input allows synchronization of voltage readings on all four channels for applications requiring coincidental readings. The same functionality can also be achieved through the remote interface.

### 1.1.1 Front panel

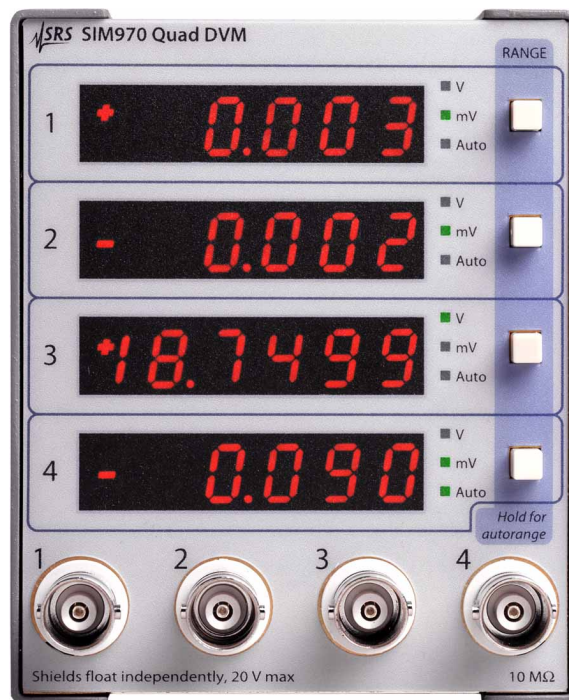

Figure 1.1: The SIM970 front panel.

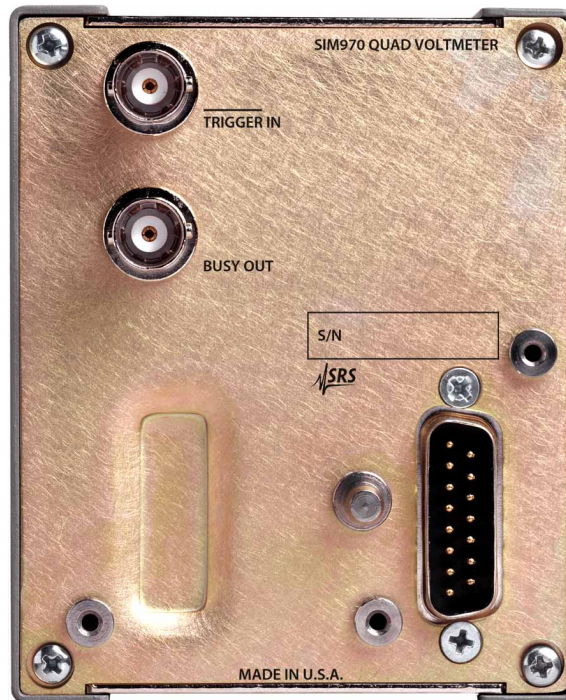

Figure 1.2: The SIM970 rear panel.

### 1.1.2 Rear panel

For a description of the rear-panel connectors and triggered operation, see Section 2.5.

## 1.2 Front-Panel Operation

**BNC** Each channel of the SIM970 measures a voltage applied between the center terminal and the shield terminal of a front-panel coaxial (BNC) connector. The center terminal is the positive input, whereas the shield is the negative input.

You can only reach specific modes of operation, which are Ranges 1 through 4, Table 2.1, from the front panel. When the instrument powers up, autoranging (Section 2.2) is turned on. When autoranging is on, the current range is determined by the magnitude of the input voltage. The automatically selected range will generally be the one that will accommodate the input voltage without overloading the input stage of the instrument, and will produce a display reading with the highest possible resolution. When autoranging is on, short front-panel button presses do nothing (except as noted below for operation from the remote interface).

In order to turn autoranging off, hold the front-panel button for a

specific channel for more than 1.5 seconds. The *Auto* annunciator will turn off. After autoranging is OFF, short button presses will switch between ranges in the sequence Range 1, Range 2, Range 3, Range 4, and back to Range 1, starting from the current range.

To turn autoranging back on, hold the button for more than 1.5 seconds. *Auto* will turn on.

The remote interface allows the user to exercise specific control over the operation of the SIM970. If, from the remote interface, the instrument had been put into an operating mode that is not one of Ranges 1 through 4 (see Section 2.1 for a description of operating modes), a front-panel button press will take the SIM970 into one of Ranges 1 through 4. Range closest to the remotely selected operating mode will be chosen. See Section 2.3.2 for more details.

The preceding description of front-panel buttons behavior also applies to EXTERNAL triggering in addition to LOCAL triggering. See Section 2.5.2 for a discussion of externally triggered behavior.

### 1.3 Input Protection

Each input to the SIM970, i.e. the voltage difference between the center terminal of each front coaxial connector and the connector's shield terminal, should not exceed  $\pm 20$  V at all times. While this voltage is exceeded, the instrument is not guaranteed to perform to its specifications. If the absolute magnitude of the input voltage exceeds 30 V with the input attenuator ON (Section 2.1.2), or 3.0 V for input attenuator OFF or OUT, an input-protection circuit will be activated (tripped), disconnecting the input voltage from the rest of the SIM970's circuitry. If this happens, the following message is displayed on the front panel:

TrIP

If the protection circuit is activated, there will be no new voltage readings available through the remote interface.

In order to clear the protection circuit, push the front-panel button for the tripped channel once. If the overload condition no longer exists, the protection circuit will turn off. The instrument will automatically attempt to clear the trip after the overload condition has occurred, but will do so only once. The trip can also be cleared from the remote interface by issuing the command TRIP.

While a channel is tripped, the SIM970 is safe and guaranteed to perform to specifications after the overload condition ceases. The

magnitude of the input voltage must never exceed  $\pm 60$  V in order for the SIM970 to be safe and return to its specified performance.

*The shield terminal of each front-panel coaxial connector is not insulated, and is potentially exposed to the user. Applying dangerous voltages to this terminal is unsafe, and may cause injury or death.*

Although the inputs to the SIM970 are galvanically isolated from the Earth (i.e. the chassis ground), it is not recommended to exceed  $\pm 20$  V between the center input terminal and the Earth, or between the shield terminal and the Earth. The instrument is not guaranteed to perform to its specifications while these values are exceeded. The SIM970 is guaranteed to perform to the specifications after the overload condition between an input terminal and the Earth ceases if none of the input terminals ever exceed  $\pm 200$  V, relative to the Earth.

## 1.4 Power-On

Upon power-on, the instrument performs a self-test. A message is displayed on the front panel during this time:

5 t a r

t i n g

U P

. . . . .

All of the green annunciator LEDs subsequently turn on. At the end of the test, the LEDs turn off and the instrument starts taking voltage readings.

The instrument does not save operation-related settings. The only non-volatile settings that are retained while the instrument is not powered are calibration values and the power line frequency: 60 Hz or 50 Hz. The latter equals the principal rejection frequency of an internal filter.

The power-on configuration of the remote interface is detailed in Section 3.3.1.

## 1.5 Restoring the Default Configuration

The default configuration of the SIM970 is Range 1 on all four channels with autoranging on (more precisely, autoranging set to ALL; see Section 2.2), with LOCAL triggering. It is the power-on configuration. To restore it, turn the SIM900 Mainframe power off and then on.

The same configuration can also be reached from the remote interface by issuing the \*RST command.



## 1.6 SIM Interface

The primary connection to the SIM970 Quad Digital Voltmeter is the rear-panel DB-15 SIM interface connector. Typically, the SIM970 is mated to a SIM900 Mainframe via this connection, either through one of the internal mainframe slots, or the remote cable interface.

It is also possible to operate the SIM970 directly, without using the SIM900 Mainframe. This section provides details on the interface.

### 1.6.1 SIM interface connector

The DB-15 SIM interface connector carries all the power and communication lines to the instrument. The connector signals are specified in Table 1.1.

Pin	Signal	Direction Src ⇒ Dest	Description
1	SIGNAL_GND	MF ⇒ SIM	Ground reference for signal
2	-STATUS	SIM ⇒ MF	Status/service request (GND=asserted, +5 V=idle)
3	RTS	MF ⇒ SIM	HW Handshake (unused in SIM970)
4	CTS	SIM ⇒ MF	HW Handshake (unused in SIM970)
5	-REF_10MHZ	MF ⇒ SIM	10 MHz reference (optional connection)
6	-5V	MF ⇒ SIM	Power supply (No connection in SIM970)
7	-15V	MF ⇒ SIM	Power supply (No connection in SIM970)
8	PS_RTN	MF ⇒ SIM	Power supply return
9	CHASSIS_GND		Chassis ground
10	TXD	MF ⇒ SIM	Async data (start bit="0"= +5 V; "1"=GND)
11	RXD	SIM ⇒ MF	Async data (start bit="0"= +5 V; "1"=GND)
12	+REF_10MHZ	MF ⇒ SIM	10 MHz reference (optional connection)
13	+5V	MF ⇒ SIM	Power supply
14	+15V	MF ⇒ SIM	Power supply (No connection in SIM970)
15	+24V	MF ⇒ SIM	Power supply (No connection in SIM970)

Table 1.1: SIM interface connector pin assignments, DB-15.

### 1.6.2 Direct interfacing

The SIM970 is intended for operation in the SIM900 Mainframe, but users may wish to directly interface the module to their own systems without the use of additional hardware.

The mating connector needed is a standard DB-15 receptacle, such as Amp part number 747909-2 (or equivalent). A clean, well-regulated supply voltage of +5.0 V DC must be provided, following the pinout specified in Table 1.1. Ground must be provided on Pin 8, with chassis ground on Pin 9. The -STATUS signal may be monitored on Pin 2 for a low-going TTL-compatible output indicating a status message. See Section 3.5 for the description of status messages.

**CAUTION**

The SIM970 has no internal protection against reverse polarity or overvoltage on the +5 V power-supply pin. A supply voltage above 5.5 V is likely to damage the instrument.

**1.6.2.1 Direct interface cabling**

If the user intends to directly wire the SIM970 independent of the SIM900 Mainframe, communication is usually possible by directly connecting the appropriate interface lines from the SIM970 DB-15 plug to the RS-232 serial port of a personal computer.<sup>1</sup> Connect RXD from the SIM970 directly to RD on the PC, TXD directly to TD, and similarly RTS→RTS and CTS→CTS. In other words, a null-modem-style cable is *not* needed.

To interface directly to the DB-9 male (DTE) RS-232 port typically found on contemporary personal computers, a cable must be made with a female DB-15 socket to mate with the SIM970, and a female DB-9 socket to mate with the PC's serial port. Separate leads from the DB-15 need to go to the power supply, making what is sometimes known as a "hydra" cable. The pin connections are given in Table 1.2.

DB-15/F to SIM970		Name
	<u>DB-9/F</u>	
10 ↔	3	TxD
11 ↔	2	RxD
	5	Computer Ground
	<u>to Power Supply</u>	
13 ↔	+5 V DC	
8,9 ↔	Ground (Supply return current)	

Table 1.2: SIM970 direct interface cable pin assignments.

**1.6.2.2 Serial settings**

The initial serial port settings at power-on are: baud rate 9600, 8 bits, no parity, 1 stop bit, and no flow control. These may be changed with the BAUD or PARI commands.

The maximum *standard* baud rate that the SIM970 supports is 38400. The minimum baud rate is 110. Above 38400, the SIM970 can be set to the following (non-RS-232-standard) baud rates: 62500, 78125, 104167, 156250. Note that these rates are typically not accessible on

<sup>1</sup> Although the serial interface lines on the DB-15 do not satisfy the minimum voltage levels of the RS-232 standard, these lines are typically compatible with desktop personal computers.

a standard PC RS-232 port, but can be used between the SIM970 and the SIM900 Mainframe.



---

## 2 Description of Operation

---

To use the whole spectrum of SIM970's capabilities, one needs to understand the instrument's operating modes. Ranges 1, 2, 3, and 4, accessible from the front panel, are only four of the operating modes available to the instrument's user.

### In This Chapter

<b>2.1</b>	<b>Operating Modes</b> . . . . .	<b>2-2</b>
2.1.1	Scale . . . . .	2-2
2.1.2	Input attenuator . . . . .	2-3
2.1.3	Autocalibration . . . . .	2-4
2.1.4	Digital filter . . . . .	2-6
<b>2.2</b>	<b>Autoranging</b> . . . . .	<b>2-8</b>
<b>2.3</b>	<b>Controlling the Mode and Auto Settings</b> . . . . .	<b>2-9</b>
2.3.1	Remote-interface control . . . . .	2-9
2.3.2	Front-panel operation . . . . .	2-9
2.3.3	Illegal modes . . . . .	2-9
<b>2.4</b>	<b>Other Instrument Features</b> . . . . .	<b>2-10</b>
2.4.1	Front-panel lockout . . . . .	2-10
2.4.2	Display blanking and messages . . . . .	2-10
<b>2.5</b>	<b>Triggering</b> . . . . .	<b>2-10</b>
2.5.1	Local triggering . . . . .	2-10
2.5.2	External triggering . . . . .	2-11
2.5.3	Remote triggering . . . . .	2-13

## 2.1 Operating Modes

An operating mode of the SIM970 is a combination of settings for the scale, the input attenuator, the autocalibration, and the digital filter. Table 2.1 summarizes the available modes.

		Scale			
		20 V	2 V	1000 mV	200 mV
<b>Attenuator OFF:</b>	Autocalibration NONE	Illegal	<b>Legal</b>	<b>Legal</b>	<b>Legal</b>
	Autocalibration GND	Illegal	<b>Range 2</b>	<b>Range 3</b>	<b>Range 4</b>
	Autocalibration GNDREF3	Illegal	Illegal	Illegal	Illegal
	Autocalibration GNDREF4	Illegal	Illegal	Illegal	Illegal
<b>Attenuator ON:</b>	Autocalibration NONE	<b>Legal</b>	<b>Legal</b>	<b>Legal</b>	<b>Legal</b>
	Autocalibration GND	<b>Legal</b>	<b>Legal</b>	<b>Legal</b>	<b>Legal</b>
	Autocalibration GNDREF3	<b>Legal</b>	<b>Legal</b>	<b>Legal</b>	<b>Legal</b>
	Autocalibration GNDREF4	<b>Range 1</b>	<b>Legal</b>	<b>Legal</b>	<b>Legal</b>
<b>Attenuator OUT:</b>	Autocalibration NONE	Illegal	<b>Legal</b>	<b>Legal</b>	<b>Legal</b>
	Autocalibration GND	Illegal	<b>Legal</b>	<b>Legal</b>	<b>Legal</b>
	Autocalibration GNDREF3	Illegal	Illegal	Illegal	Illegal
	Autocalibration GNDREF4	Illegal	Illegal	Illegal	Illegal

For LOCAL triggering

Table 2.1: Operating modes of the SIM970.

For all legal modes shown, the digital filter may be either enabled or disabled. For Ranges 1 through 4, digital filter settings are:

Range	Digital filter
1	OFF
2	OFF
3	OFF
4	ON

Ranges 1 through 4 are the only operating modes accessible through the front panel. A much richer variety of modes are available through the remote interface. The next Section, “Remote Operation”, discusses the commands necessary to put some or all of the channels of a SIM970 into a given mode. These commands are also briefly discussed in Sections 2.1.1 through 2.1.4 and Section 2.2, which describe the aspects of operation these settings affect.

### 2.1.1 Scale

The scale setting for a given channel is the position of the decimal point on the front-panel display for this channel.

Scale setting	Front-panel display format
20 V	$\pm 19.9999$ V
2 V	$\pm 1.99999$ V
1000 mV	$\pm 999.99$ mV
200 mV	$\pm 199.999$ mV

The scale setting for a channel is related to the range the channel may be on, but the two terms are not equivalent. A range is an operating mode and consists of other settings in addition to the scale setting. For Ranges 1 through 4, accessible from the front panel, there is a one-to-one correspondence between the range and the scale. However, with the help of the remote interface, the scale for a given mode can be set to every scale in Table 2.1 that is allowed. In other words, the position of the decimal point on the front-panel display does not uniquely determine the input attenuator, the autocalibration, and the digital filter settings if the remote interface is utilized.

To change the scale from the remote interface, issue the SCAL command.

If the reading overloads the maximum value that is possible to display on a given scale, the front-panel display format can change to accommodate the higher reading. If such accommodation is not possible, the following is displayed:

+ 01 .    —or—    - 01 .

### 2.1.2 Input attenuator

The internal analog-to-digital converter of the SIM970 can only sample a voltage between  $-2.5$  and  $+2.5$  volts. In order to measure higher voltages, the input signal must be attenuated inside the SIM970. The input attenuator is a 1 : 10 voltage divider that can be inserted into the signal path:

The input attenuator can be ON, in which case the voltage sampled by the converter is  $1/10$ th of the input voltage; it can be OFF, in which case the input voltage is sampled directly; and it can be OUT, in which case the voltage is also sampled directly and the resistors that comprise the attenuator are disconnected from the input signal. For the attenuator OFF and for the attenuator ON, the input resistance of a channel is equal to  $10\text{ M}\Omega$ . For the attenuator OUT, the resistance exceeds  $3\text{ G}\Omega$ .

To change the input attenuator setting from the remote interface, use the DVDR command.

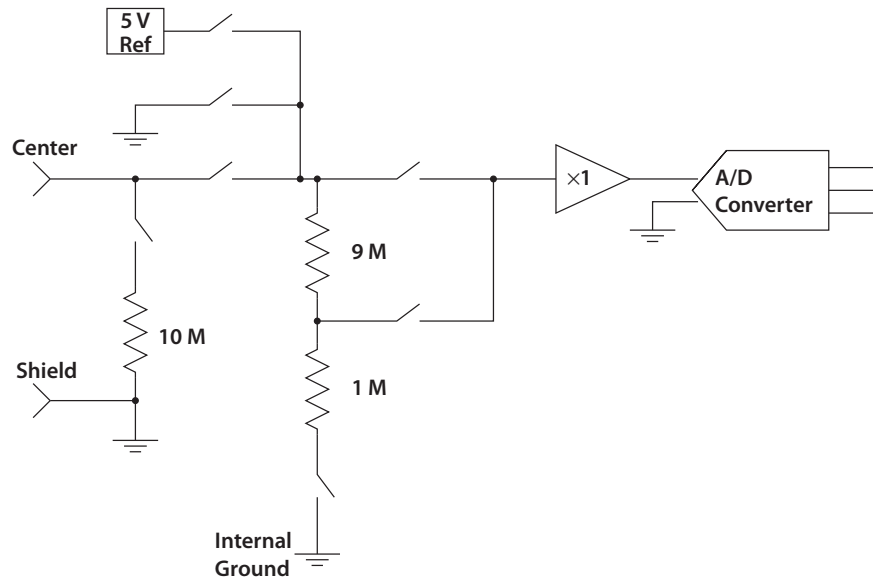

Figure 2.1: Simplified schematic of the input stage circuit of the SIM970.

*Not all scale and autocalibration settings are compatible with input attenuator OFF or OUT. See Section 2.3.3, "Illegal Modes", for more details.*

The format of the data available through the remote interface is uniquely determined by the attenuator setting. That is, the settings for the scale and the autocalibration do not affect the position of the decimal point in the data that the SIM970 supplies through the remote interface.

Input attenuator setting	Remote-interface data format
OFF	*Y.XXXXXXX
ON	*YX.XXXXXX
OUT	*Y.XXXXXXX

\* is either the minus character ("−") or is the space (" ");  
 Y is the character "0", "1", or "2";  
 X is one of the characters "0" through "9".

### 2.1.3 Autocalibration

Autocalibration corrects the voltage reading for two kinds of errors: offset error and gain error. The offset error results in a constant offset term added to the true value of the input voltage:

$$(\text{voltage read by the instrument}) = (\text{real voltage}) + (\text{offset}), \text{ where } (\text{offset}) \neq 0.$$

gain error The gain error results in the voltage reading multiplied by some fac-



tor, compared to the true value:

(voltage read by the instrument) = (real voltage) · (gain), where (gain) ≠ 1.

Most of the gain error is caused by resistance drift in the input attenuator. Some of it is due to gain errors in the circuitry that follows the input attenuator, and to errors in the converter.

Four autocalibration regimes are possible.

<b>Autocalibration</b>	Error corrected	How often	For other settings
NONE	Offset	Once	Every combination
	Gain	Once	Attenuator ON
	Gain	Never	Attenuator OFF or OUT
GND	Offset	Continuously	Every combination
	Gain	Once	Attenuator ON
	Gain	Never	Attenuator OFF or OUT
GNDREF3	Offset	Continuously	Every combination
	Gain	Continuously	Every combination
GNDREF4	Offset	Continuously	Every combination
	Gain	Continuously	Every combination

Autocalibration is performed by the instrument by taking alternating readings of the input voltage, the internal ground, and the internal reference; the ground and reference readings are taken as these voltages pass through the same signal path as the input voltage. Therefore, it is possible to calibrate the input attenuator and subsequent circuitry by comparing the attenuated reference signal with the original.

The sequence of readings for each of the autocalibration regimes is as follows:

<b>Autocalibration</b>	Sequence of readings
NONE	<b>Input</b>
GND	<b>Input, Ground</b>
GNDREF3	<b>Input, Reference, Ground</b>
GNDREF4	<b>Input, Reference, Input, Ground</b>

Table 2.2: Autocalibration reading sequences for the SIM970.

After each complete sequence of readings, the front-panel displays are updated with the new value of the input voltage, corrected for the offset and (if available) gain errors, and the new value of the input voltage becomes available to the remote interface. An exception to this rule is the regime GNDREF4, in which the new corrected value is

shown on the displays and is available to the remote interface after a **Reference** reading is taken, and after a **Ground** reading is taken.

For errors corrected “once”, a reading of the internal ground and/or reference is taken at the time the mode switches to the present mode. This reading is used to correct all subsequent input voltage readings.

For LOCAL triggering<sup>1</sup>, the internal sampling frequency of the instrument is fixed at 7.2 Hz if the power-line frequency (FPLC) is 60 Hz, and at 6.0 Hz if FPLC is 50 Hz. Therefore, the frequency at which corrected voltage readings are displayed on the front panel and are available to the remote interface depends on the autocalibration regime as follows:

Autocalibration	FPLC (Hz)		
	60	50	
NONE	7.2	6.0	readings/s
GND	3.6	3.0	readings/s
GNDREF3	2.4	2.0	readings/s
GNDREF4	3.6	3.0	readings/s

The display update frequency for Ranges 1 through 4 is the same, 3.6 readings per second if FPLC is 60 Hz and 3.0 readings per second if FPLC is 50 Hz.

In order to change the autocalibration regime from the remote interface, use the CHOP command.

For maximum accuracy, choose autocalibration regime GND if the input attenuator is OFF or OUT, and the regime GNDREF3 or GNDREF4 if the attenuator is ON. Choosing autocalibration GND or NONE for attenuator ON results in a somewhat decreased reading noise, at the expense of an increased reading drift.

#### 2.1.4 Digital filter

The digital filter produces a running exponential average of the results of input voltage readings. The acceptable settings for the filter are ON and OFF. For each legal combination of the scale, the attenuator, and the autocalibration settings, it is legal to have the filter ON and it is legal to have the filter OFF. Range 4 has the filter ON, whereas Ranges 1 through 3 turn the filter OFF.<sup>2</sup>

The input to the filter is input voltage readings corrected for the offset error and the gain error. Numerically, the filter is a simple IIR (infinite-impulse response) algorithm with a time constant

<sup>1</sup> See Section 2.5 for the description of the instrument triggering options.

<sup>2</sup> This applies to LOCAL triggering only; see Section 2.5 for the description of the instrument triggering options.

of 8.0 readings. This time constant equals 2.22/2.67 seconds for FPLC = 60 Hz/50 Hz if the autocalibration regime is GND or GNDREF4; the time constant is 1.11/1.33 seconds if the autocalibration is NONE. These time values are only valid for LOCAL triggering with its fixed sample rate.

Turning the filter ON reduces the reading-to-reading noise. The filter also increases the instrument's settling time. The filter is temporarily deactivated if there is a large change in the input voltage, so as to improve the settling characteristic.

In order to change the digital filter setting from the remote interface, issue the FLTR command.

In addition to the operating mode, the behavior of the instrument is determined by the autoranging settings; the front-panel lockout and the display blanking and display messaging options; and the trigger mode.

## 2.2 Autoranging

With front-panel operation, autoranging can be on or off. If the autoranging is ON, the magnitude of the input voltage determines the current range for a given channel (one of Ranges 1 through 4 in Table 2.1). The SIM970 under- and over-ranges according to the threshold specifications on Page vii.

Under the remote interface, the instrument's user can achieve a finer degree of control over the autoranging behavior. There are four *auto bits*, set by the command **AUTO**:

Weight	Bit	Token	Meaning
1	0	SCALE	Input voltage determines the scale
2	1	DIVIDER	Current scale determines the input attenuator setting
4	2	CHOP	Current scale determines the autocalibration regime
8	3	FILTER	Current scale determines the digital filter setting

One or several bits can be set by **AUTO**. For example, the behavior of the instrument after issuing **AUTO 1, 5** will be as follows: For Channel 1, the input voltage will set the scale, which, in turn, will set the autocalibration regime to the one that corresponds to the range for the current scale in Table 2.1. However, the complete operating mode will not be set to this range. In this example, the position of the decimal point on the display of Channel 1 and the channel's autocalibration regime will change with the magnitude of the input voltage but neither the input attenuator nor the digital filter settings will. If, further in this example, the input attenuator for Channel 1 has been set to ON and the digital filter set to OFF, the channel's operating mode will respond in the following way to an increase in the input voltage:

Input voltage	Scale	Attenuator	Autocalibration	Filter
0 mV to +199.999 mV	200 mV	ON	GND	OFF
+200.00 mV to +999.99 mV	1000 mV	ON	GND	OFF
+1.00000 V to +1.99999 V	2 V	ON	GND	OFF
+2.0000 V to +19.9999 V	20 V	ON	GNDREF4	OFF

*Unlike with other commands, the behavior of **AUTO** is different with number arguments and with tokens. See **AUTO** for more details.*

Under front-panel operation, all of the auto bits are off or all of

them are on. To turn all the bits off from the remote interface, issue `AUTO n, 0` or `AUTO n, OFF`, where *n* is the channel number. To turn all of them on, issue `AUTO n, 15` or `AUTO n, ALL`.

The front-panel *Auto* LED annunciator for a given channel is active if `AUTO` is not `0` for the channel.

## 2.3 Controlling the Mode and Auto Settings

### 2.3.1 Remote-interface control

The scale, input attenuator, autocalibration, and digital filter settings for each channel can be controlled independently from the remote interface. When issuing the respective commands, the user should be aware of illegal modes (Table 2.1 and Section 2.3.3).

In order to get every channel of the instrument into one of Ranges 1 through 4 while under remote-interface control, issue the command `LOCL`. The operating mode for each channel will change to the range appropriate for the channel's currently selected scale (Table 2.1). If one or several of the auto bits for a channel were on, all of the auto bits for this channel will turn on; otherwise `AUTO` for the channel will be `OFF`.

Alternatively, a front-panel button push will return the instrument into one of the Ranges. See the next section.

### 2.3.2 Front-panel operation

If the front-panel button for a channel is pushed while the SIM970 is under remote control, the instrument will return each channel into one of the Ranges of Table 2.1 (Table 2.3 for non-local triggering). This is done by turning all of the `AUTO` bits for the channel `ON` if one or several of them were on, and leaving them `OFF` if they were `0`. Autoranging will subsequently select the appropriate range.

### 2.3.3 Illegal modes

Having control over separate components of the operating mode makes it possible to request an illegal mode (Table 2.1, Table 2.3 for non-local triggering). Illegal modes are accepted via forcing the input attenuator setting to `ON` and leaving the rest of the proposed settings intact. A Device-Dependent Error will be issued with a `DDE_ILLEGAL_MODE` return code (see the command `LDDE?` for more details).

## 2.4 Other Instrument Features

### 2.4.1 Front-panel lockout

The command **FRNT** makes it possible to enable or disable the response of the instrument to front-panel events. With **FRNT OFF** for a particular channel, front-panel button pushes for that channel have no effect—**FRNT ON** must be issued to regain front-panel control.

### 2.4.2 Display blanking and messages

It is possible to disable the front-panel display for one or all channels. Updates to the channel's display and all multiplexed electrical activity at the seven-segment digits will stop, and the displays will turn dark. Use the command **DISX** to turn displays on and off.

After the updates to the display have been turned off, it is possible to paint alphanumeric messages on the display. See the command **MESG** for more information. If the updates have not been turned off by **DISX *n*, OFF** (*n* is channel number) prior to issuing **MESG**, the message will only stay on the display for one display cycle; a fraction of a second under local triggering, but possibly many seconds for **EXTERNAL** or **REMOTE** triggering.

## 2.5 Triggering

**trigger** A *trigger* is an event that signals the SIM970 to take one or several voltage readings. The SIM970 has three *trigger modes*: **LOCAL**, **EXTERNAL**, and **REMOTE**. To change the mode, issue the **TMOD** command.

For all legal modes shown in Table 2.3, the digital filter may be either enabled or disabled. For Ranges 1 through 4, digital filter settings are:

Range	Digital filter
1	OFF
2	OFF
3	OFF
4	OFF

### 2.5.1 Local triggering

In the locally triggered mode, the instrument takes continuous readings. The **BUSY** output is always **HIGH**. Although the four channels take readings synchronously, there is no alignment between the samples of the input voltage. That is, each of the four channels can be in each of the legal autocalibration settings: when, e.g., Channel 1 is taking a reading of the input voltage, Channel 2 can be taking a

		Scale			
		20 V	2 V	1000 mV	200 mV
<b>Attenuator OFF:</b>	Autocalibration NONE	Illegal	<b>Legal</b>	<b>Legal</b>	<b>Legal</b>
	Autocalibration GND	Illegal	<b>Range 2</b>	<b>Range 3</b>	<b>Range 4</b>
	Autocalibration GNDREF3	Illegal	Illegal	Illegal	Illegal
	Autocalibration GNDREF4	Illegal	Illegal	Illegal	Illegal
<b>Attenuator ON:</b>	Autocalibration NONE	<b>Legal</b>	<b>Legal</b>	<b>Legal</b>	<b>Legal</b>
	Autocalibration GND	<b>Legal</b>	<b>Legal</b>	<b>Legal</b>	<b>Legal</b>
	Autocalibration GNDREF3	<b>Range 1</b>	<b>Legal</b>	<b>Legal</b>	<b>Legal</b>
	Autocalibration GNDREF4	<b>Legal</b>	<b>Legal</b>	<b>Legal</b>	<b>Legal</b>
<b>Attenuator OUT:</b>	Autocalibration NONE	Illegal	<b>Legal</b>	<b>Legal</b>	<b>Legal</b>
	Autocalibration GND	Illegal	<b>Legal</b>	<b>Legal</b>	<b>Legal</b>
	Autocalibration GNDREF3	Illegal	Illegal	Illegal	Illegal
	Autocalibration GNDREF4	Illegal	Illegal	Illegal	Illegal

For EXTERNAL and REMOTE triggering

Table 2.3: Operating modes of the SIM970 for non-local triggering.

reading of the local ground. Voltage readings are made available to the display and the remote interface at the time an autocalibration sequence (Table 2.2) is complete on a particular channel. As a consequence, under certain conditions the displays can be seen updating the readings “out of phase” with one another. If voltage readings for several channels are requested from the remote interface, these can also arrive “out of phase”.

The instrument powers up into the locally triggered mode. To switch to local triggering from one of the other modes, issue TMOD LOCAL.

### 2.5.2 External triggering

If the instrument is in the locally triggered mode and receives a TTL LOW at the –TRIGGER input, the SIM970 switches to its external trigger mode. In this mode, if the instrument is not busy taking reading sequences (i.e. the BUSY output is LOW), each LOW-going edge at the –TRIGGER input causes one or several sequences of readings to be taken on all channels.

Unlike the behavior in the LOCAL mode, autocalibration sequences on the four channels are aligned. That is, a certain interval of time (called *trigger latency*) after the LOW-going edge is received, all four channels will start taking a reading of the input voltage at the same time. After this reading is taken, the channels will follow with taking the necessary autocalibration readings in each channel’s sequence. Clearly a situation is possible in which some channels have more

readings to take than others (Table 2.2). In this case, channels that have less readings to take, pad their sequences with readings of the input voltage, which are ignored. The result of a sequence of readings on a particular channel is available to the displays and the remote interface as soon as the sequence on that channel is complete. The BUSY output stays HIGH from the time an external trigger is received until the last reading of the longest sequence is complete.

The following is an example of autocalibration sequences under EXTERNAL triggering, with different settings for the four channels:

Channel	1	2	3	4
<b>Autocalibration</b>	NONE	GND	GNDREF3	GNDREF4
Sequence	<b>Input</b> Input Input Input	Input <b>Ground</b> Input Input	Input Reference <b>Ground</b> Input	Input Reference Input <b>Ground</b>

where bold face indicates the reading after which the front-panel displays and the remote interface are updated.

It is possible to take more than one sequence of readings for each external trigger. The number of sequences to take is set by the remote command TCNT; this number is 1 upon power-on. The beginnings of the sequences will be separated by the *trigger period*, set by the command TPER. If the period is too short for the longest reading sequence among all channels to complete, a device error will be generated and the period will be reset to its default value, 1000 ms. The period is equal to this default value upon power-on.

If TCNT? is greater than one, the BUSY output will stay HIGH for the whole duration of the ensemble of reading sequences caused by a single external trigger event, including the “waiting/idle” time between the sequences.

The instrument buffers one external trigger event. If an external trigger arrives when the SIM970 is busy, that is, the BUSY output is HIGH, this trigger will be serviced after the triggered readings are complete. All additional triggers received afterwards and while the instrument is still BUSY will be ignored. If a trigger is buffered, the BUSY output will become LOW when it normally would, and will stay LOW for a minimum of 10 ms. At the end of this period, the output will go HIGH and the next triggered reading sequence will start. Triggered reading sequences cannot be interrupted. They always complete.

When the first EXTERNAL trigger is received while the instrument is in the local trigger mode, the current locally triggered sequences will complete. This first trigger will be serviced as a buffered trigger.



In order to switch to or from EXTERNAL triggering, issue the TMOD command. If the remote interface is not available, the only way from EXTERNAL to LOCAL triggering is through a power cycle.

The external –TRIGGER input is active LOW, and hence triggers can be caused by simply shorting the center terminal of this BNC connector to its shield. However, the trigger signal must be debounced. *Shorting the two terminals of the –TRIGGER input without debouncing will most likely cause multiple signal edges and hence multiple triggers, of which the first two will be recognized: the second one will be buffered.*

The effect of the front-panel buttons in the externally triggered mode is the same as it is under local triggering. Table 2.3 details the available ranges. However, several readings typically need to be taken until the operating mode change is complete. During this change, dashes will be displayed on the front panel, with the decimal point in the position expected after the scale change. The first reading that

- - . - - - -

appears on the display and at the remote interface after the dashes will have been taken under the new range settings.

### 2.5.3 Remote triggering

The behavior of the SIM970 under remote triggering is identical to that under external triggering, with only one difference. Instead of an external TTL LOW edge at the –TRIGGER input, the source of a REMOTE trigger is the receipt of a \*TRG command at the remote interface.

External triggers received while under remote triggering will be ignored (and the other way around), with the following exception. If the SIM970 is “idling” after a complete reading sequence under EXTERNAL triggering, and TMOD REMOTE is received, it is necessary to give one more external trigger after that in order for the trigger mode change to complete. If an additional TTL trigger is not practical, the transition EXTERNAL→REMOTE can be made by first issuing TMOD LOCAL, followed by TMOD REMOTE. The same applies to switching the mode from REMOTE to EXTERNAL: in the latter case, issue one \*TRG after TMOD EXTERNAL.



---

## 3 Remote Operation

---

This chapter describes operating the SIM970 over the serial interface.

### In This Chapter

<b>3.1</b>	<b>Index of Common Commands</b>	<b>3-2</b>
<b>3.2</b>	<b>Alphabetic List of Commands</b>	<b>3-4</b>
<b>3.3</b>	<b>Introduction</b>	<b>3-6</b>
3.3.1	Power-on configuration	3-6
3.3.2	Buffers	3-6
3.3.3	Device Clear	3-6
<b>3.4</b>	<b>Commands</b>	<b>3-6</b>
3.4.1	Command syntax	3-7
3.4.2	Notation	3-8
3.4.3	General commands	3-9
3.4.4	Measure commands	3-9
3.4.5	Configuration commands	3-10
3.4.6	Trigger commands	3-12
3.4.7	Status commands	3-13
3.4.8	Interface commands	3-14
3.4.9	Serial communication commands	3-17
<b>3.5</b>	<b>Status Model</b>	<b>3-18</b>
3.5.1	Status Byte (SB)	3-19
3.5.2	Service Request Enable (SRE)	3-19
3.5.3	Standard Event Status (ESR)	3-20
3.5.4	Standard Event Status Enable (ESE)	3-20
3.5.5	Communication Error Status (CESR)	3-20
3.5.6	Communication Error Status Enable (CESE)	3-21
3.5.7	Channel Status (CHSR)	3-21
3.5.8	Channel Status Enable (CHSE)	3-22

### 3.1 Index of Common Commands

Symbol	Definition
<i>i</i>	Bit number (0–7)
<i>j, k</i>	Unsigned integer
<i>n</i>	Channel number (1–4); <i>n</i> = 0 means “all”
<i>s</i>	Character string
<i>z</i>	Literal token
(?)	Required for queries; illegal for set commands
<i>var</i>	Parameter always required
{ <i>var</i> }	Required parameter for set commands; illegal for queries
[ <i>var</i> ]	Optional parameter for both set and query forms

---

#### General

HELP(?)                    3-9    Instrument Help

---

#### Measure

VOLT? *n* [, *j*]            3-9    Measured Voltage  
 VGND? *n*                    3-9    Measured Ground  
 VREF? *n*                    3-9    Measured Reference  
 TRIP(?) *n*                 3-9    Overvoltage Trip  
 SOUT                         3-9    Stop Streaming  
 MESH *n* [, *s*]             3-10    Display Message

---

#### Configuration

LOCL                         3-10    Local Interface  
 FPLC(?) {*j*}                3-10    Power Line Cycle Frequency  
 DISX(?) *n* {, *z*}            3-10    Display Enable/Disable  
 FRNT(?) *n* {, *z*}            3-11    Front Panel Enable  
 SCAL(?) *n* {, *j*}            3-11    Display Scale  
 DVDR(?) *n* {, *z*}            3-11    Input Attenuator  
 CHOP(?) *n* {, *z*}            3-11    Autocalibration  
 FLTR(?) *n* {, *z*}            3-11    Digital Filter  
 AUTO(?) *n* {, *z*}            3-11    Autoranging State

---

#### Trigger

TMOD(?) {*z*}                3-12    Trigger Mode  
 TCNT(?) {*j*}                3-12    Trigger Count  
 TREM(?) {*j*}                3-12    Trigger Count Remaining  
 TPER(?) {*k*}                3-13    Trigger Period  
 \*TRG                         3-13    Trigger

---

**Status**

*CLS	3 – 13	Clear Status
*STB? [i]	3 – 13	Status Byte
*SRE(?) [i,] {j}	3 – 13	Service Request Enable
*ESR? [i]	3 – 13	Standard Event Status
*ESE(?) [i,] {j}	3 – 13	Standard Event Status Enable
CESR? [i]	3 – 14	Communication Error Status
CESE(?) [i,] {j}	3 – 14	Communication Error Status Enable
CHSR? [i]	3 – 14	Channel Status
CHSE(?) [i,] {j}	3 – 14	Channel Status Enable
PSTA(?) {z}	3 – 14	Pulse –STATUS Mode
LBTN?	3 – 14	Last Button

---

**Interface**

*RST	3 – 15	Reset
*IDN?	3 – 15	Identify
*TST?	3 – 15	Self Test
*OPC(?)	3 – 15	Operation Complete
CONS(?) {z}	3 – 16	Console Mode
LEXE?	3 – 16	Execution Error
LCME?	3 – 16	Command Error
LDDE?	3 – 17	Device Error
TOKN(?) {z}	3 – 17	Token Mode
TERM(?) {z}	3 – 17	Response Termination

---

**Serial Communications**

BAUD(?) {k}	3 – 17	Baud Rate
PARI(?) {z}	3 – 17	Parity

### 3.2 Alphabetic List of Commands

---

**★**

*CLS	3 – 13	Clear Status
*ESE(?) [i,] {j}	3 – 13	Standard Event Status Enable
*ESR? [i]	3 – 13	Standard Event Status
*IDN?	3 – 15	Identify
*OPC(?)	3 – 15	Operation Complete
*RST	3 – 15	Reset
*SRE(?) [i,] {j}	3 – 13	Service Request Enable
*STB? [i]	3 – 13	Status Byte
*TRG	3 – 13	Trigger
*TST?	3 – 15	Self Test

---

**A**

AUTO(?) n {, z}	3 – 11	Autoranging State
-----------------	--------	-------------------

---

**B**

BAUD(?) {k}	3 – 17	Baud Rate
-------------	--------	-----------

---

**C**

CESE(?) [i,] {j}	3 – 14	Communication Error Status Enable
CESR? [i]	3 – 14	Communication Error Status
CHOP(?) n {, z}	3 – 11	Autocalibration
CHSE(?) [i,] {j}	3 – 14	Channel Status Enable
CHSR? [i]	3 – 14	Channel Status
CONS(?) {z}	3 – 16	Console Mode

---

**D**

DISX(?) n {, z}	3 – 10	Display Enable/Disable
DVDR(?) n {, z}	3 – 11	Input Attenuator

---

**F**

FLTR(?) n {, z}	3 – 11	Digital Filter
FPLC(?) {j}	3 – 10	Power Line Cycle Frequency
FRNT(?) n {, z}	3 – 11	Front Panel Enable

---

**H**

HELP(?)	3 – 9	Instrument Help
---------	-------	-----------------

---

**L**

LBTN?	3 – 14	Last Button
LCME?	3 – 16	Command Error

---

---

LDDE?	3-17 Device Error
LEXE?	3-16 Execution Error
LOCL	3-10 Local Interface

---

**M**

MESG <i>n</i> [, <i>s</i> ]	3-10 Display Message
-----------------------------	----------------------

---

**P**

PARI(?) { <i>z</i> }	3-17 Parity
PSTA(?) { <i>z</i> }	3-14 Pulse -STATUS Mode

---

**S**

SCAL(?) <i>n</i> {, <i>j</i> }	3-11 Display Scale
SOUT	3-9 Stop Streaming

---

**T**

TCNT(?) { <i>j</i> }	3-12 Trigger Count
TERM(?) { <i>z</i> }	3-17 Response Termination
TMOD(?) { <i>z</i> }	3-12 Trigger Mode
TOKN(?) { <i>z</i> }	3-17 Token Mode
TPER(?) { <i>k</i> }	3-13 Trigger Period
TREM(?) { <i>j</i> }	3-12 Trigger Count Remaining
TRIP(?) <i>n</i>	3-9 Overvoltage Trip

---

**V**

VGND? <i>n</i>	3-9 Measured Ground
VOLT? <i>n</i> [, <i>j</i> ]	3-9 Measured Voltage
VREF? <i>n</i>	3-9 Measured Reference

### 3.3 Introduction

Remote operation of the SIM970 is through a simple command language documented in this chapter. Both set and query forms of most commands are supported, allowing the user complete control of the amplifier from a remote computer, either through the SIM900 Mainframe or directly via RS-232 (see Section 1.6.2.1).

See Table 1.1 for the specification of the DB-15 SIM Interface Connector.

#### 3.3.1 Power-on configuration

The initial settings for the remote interface are 9600 baud with no parity and no flow control, and with local echo disabled (CONS OFF).

Where appropriate, the power-on default value for parameters is listed in **boldface** in the command descriptions.

#### 3.3.2 Buffers

The SIM970 stores incoming bytes from the host interface in a 16-byte input buffer. Characters accumulate in the input buffer until a command terminator (either <CR> or <LF>) is received, at which point the message is parsed and executed. Query responses from the SIM970 are buffered in a 64-byte output queue.

If the input buffer overflows, then all data in *both* the input buffer and the output queue are discarded, and an error is recorded in the CESR and ESR status registers.

#### 3.3.3 Device Clear

The SIM970 host interface can be asynchronously reset to its power-on configuration by sending an RS-232-style <break> signal. From the SIM900 Mainframe, this is accomplished with the SRST command; if directly interfacing via RS-232, then use a serial break signal. After receiving the Device Clear, the interface is reset to 9600 baud and the CONS mode is turned OFF. Note that this *only* resets the communication interface; the basic function of the SIM970 is left unchanged; to reset the voltmeter, use \*RST.

The Device Clear signal will also terminate all streaming outputs from the SIM970 due to a VOLT? query of multiple readings.

### 3.4 Commands

This section provides syntax and operational descriptions for remote commands.



### 3.4.1 Command syntax

The four letter mnemonic (shown in **CAPS**) in each command sequence specifies the command. The rest of the sequence consists of parameters.

Commands may take either *set* or *query* form, depending on whether the “?” character follows the mnemonic. *Set only* commands are listed without the “?”, *query only* commands show the “?” after the mnemonic, and *optionally query* commands are marked with a “(?)”.

Parameters shown in { } and [ ] are not always required. Parameters in { } are required to set a value, and should be omitted for queries. Parameters in [ ] are optional in both set and query commands. Parameters listed without surrounding characters are always required.

Do *not* send ( ) or { } or [ ] as part of the command.

Multiple parameters are separated by commas. Multiple commands may be sent on one command line by separating them with semicolons (;) so long as the input buffer does not overflow. Commands are terminated by either <CR> or <LF> characters. Null commands and whitespaces are ignored. Execution of the command does not begin until the command terminator is received.

tokens *Token* parameters (generically shown as z in the command descriptions) can be specified either as a keyword or as an integer value. Command descriptions list the valid keyword options, with each keyword followed by its corresponding integer value. For example, to set the response termination sequence to <CR>+<LF>, the following two commands are equivalent:

TERM CRLF      —or—      TERM 3

For queries that return token values, the return format (keyword or integer) is specified with the TOKN command.

### 3.4.2 Notation

The following table summarizes the notation used in the command descriptions:

Symbol	Definition
<i>i</i>	Bit number (0-7)
<i>j, k</i>	Unsigned integer
<i>n</i>	Channel number (1-4); <i>n</i> = 0 means "all"
<i>s</i>	Character string
<i>z</i>	Literal token
(?)	Required for queries; illegal for set commands
<i>var</i>	Parameter always required
{ <i>var</i> }	Required parameter for set commands; illegal for queries
[ <i>var</i> ]	Optional parameter for both set and query forms

### 3.4.3 General commands

---

HELP(?)	Instrument Help Outputs a condensed version of Section 3.4 to the remote interface. HELP may be used with or without the query sign, with the same effects.
---------	---

### 3.4.4 Measure commands

For measure commands that accept a channel number  $n$ , setting  $n = 0$  selects all four channels. Replies to commands that query all four channels are separated by commas.

---

VOLT? $n$ [ $,j$ ]	Measured Voltage Query the voltage for Channel $n$ . If $j$ is specified, it denotes the number of successive readings to return (VOLT? $n, 1$ is equivalent to VOLT? $n$ ). If $j = 0$ is specified, then readings are returned continuously until the SOUT command is sent. The maximum $j = 65535$ . The first value is returned immediately following the query; this value is the last known measured voltage, corrected for the offset and gain errors. Subsequent readings are sent to the remote interface when autocalibration sequences on the particular channel complete (Section 2.1.3).
VGND? $n$	Measured Ground Query the ground voltage (offset correction) for Channel $n$ .
VREF? $n$	Measured Reference Query the +5 V reference voltage (gain correction) for Channel $n$ .
TRIP(?) $n$	Overvoltage Trip Clear (query) the overvoltage trip status of Channel $n$ .
SOUT	Stop Streaming Turn off the continuous output of multiple VOLT? responses.

---

MESG $n$ [, $s$ ]	<p>Display Message</p> <p>Display a text message on Channel <math>n</math>, or clear the message if <math>s</math> is not specified. The message is overwritten by the next reading display unless DISX <math>n</math>, OFF is set.</p> <p>The message parameter <math>s</math> is given without special quotation marks, but is subject to the following formatting rules:</p> <ul style="list-style-type: none"> <li>• <math>s</math> is case-insensitive.</li> <li>• The first character of <math>s</math> must be either <math>_</math>, 1, or I.</li> <li>• Use the <math>_</math> character to specify a blank space.</li> <li>• Valid display characters are the digits 0123456789, the letters ABCDEFGHIJLNOPQRSTUYZ, and the <math>.</math> and <math>-</math> marks. The letters K, M, V, W, and X are not displayable, and will appear as blanks. Letters may be displayed in lowercase or in uppercase.</li> </ul> <p>Note that the leading <math>\pm</math> indicator cannot be illuminated with the MESG command; this allows the user to easily distinguish reading results from remote messages.</p>
-------------------	--

### 3.4.5 Configuration commands

For configuration commands that accept a channel number  $n$ , setting  $n = 0$  selects all four channels. Replies to commands that query all four channels are separated by commas.

---

LOCL	<p>Local Interface</p> <p>Set the SIM970 into local mode. All channels are placed into one of the four Range settings (Table 2.1), and triggers are set to LOCAL (automatic trigger).</p>
FPLC(?) { $j$ }	<p>Power Line Cycle Frequency</p> <p>Set (query) the power-line rejection frequency {to <math>j = (50, 60)</math>}, in Hz.</p> <p>The FPLC value is retained in non-volatile memory, and is <i>not</i> modified by a power-on reset.</p>
DISX(?) $n$ {, $z$ }	<p>Display Enable/Disable</p> <p>Set (query) the display for Channel <math>n</math> {to <math>z = (OFF\ 0, ON\ 1)</math>}.</p> <p>When DISX <math>n</math>, ON is set, each new reading result is presented on the front-panel display upon the completion of an autocalibration sequence. DISX <math>n</math>, OFF initially blanks the display, but then allows MESG messages to be presented.</p>

---

---

FRNT(?) <i>n</i> {, <i>z</i> }	<p>Front Panel Enable</p> <p>Set (query) the front-panel lockout status for Channel <i>n</i> {to <i>z</i> = (OFF 0, ON 1)}. When FRNT <i>n</i>, OFF is sent, the SIM970 stops responding to all front-panel button presses for Channel <i>n</i>.</p>
SCAL(?) <i>n</i> {, <i>j</i> }	<p>Display Scale</p> <p>Set (query) the front-panel display scale for Channel <i>n</i> {to <i>j</i> = (20, 2, 1000, or 200)}. The setting <i>j</i> is one count greater than the maximum displayable value, corresponding to 20 V, 2 V, 1000 mV, or 200 mV.</p>
DVDR(?) <i>n</i> {, <i>z</i> }	<p>Input Attenuator</p> <p>Set (query) the 1 : 10 input attenuator setting for Channel <i>n</i> {to <i>z</i> = (OFF 0, ON 1, or OUT 2)}.</p> <p>When ON, the 10 MΩ 1 : 10 input attenuator is switched into the signal path, permitting input signals up to ±20 V to be measured without tripping the protection circuitry. When OFF or OUT, the input signal is not attenuated, and input signals in excess of ±2 V will trip the protection circuitry.</p> <p>The difference between DVDR OFF and OUT is the input resistance of the channel. When OFF, the channel still presents a 10 MΩ load to the user; when the attenuator is OUT, the input impedance is &gt; 3 GΩ.</p>
CHOP(?) <i>n</i> {, <i>z</i> }	<p>Autocalibration</p> <p>Set (query) the autocalibration regime for Channel <i>n</i> {to <i>z</i> = (NONE 0, GND 1, GNDREF4 2, or GNDREF3 3)}. See Section 2.1.3 for details.</p>
FLTR(?) <i>n</i> {, <i>z</i> }	<p>Digital Filter</p> <p>Set (query) the digital filter state for Channel <i>n</i> {to <i>z</i> = (OFF 0, ON 1)}.</p>
AUTO(?) <i>n</i> {, <i>z</i> }	<p>Autoranging State</p> <p>Set (query) the autoranging settings for Channel <i>n</i>.</p> <p>The parameter <i>z</i> is interpreted differently for integer or token values. Valid tokens are:</p> <p>OFF : Turns all autoranging control bits (auto bits) off.</p> <p>ALL : Turns all auto bits on.</p> <p>SCALE : Enables automatic scale selection (the scale is determined by the voltage reading).</p>

---

**DIVIDER** : Enables automatic input attenuator selection (the attenuator is set based on the scale value).

**CHOP** : Enables automatic selection of the autocalibration regime (autocalibration is set based on the scale value).

**FILTER** : Enables automatic digital filter selection (the filter is set based on the scale value).

With the exception of **OFF** and **ALL**, each token only turns on a single control bit, while leaving the remaining bits unchanged.

When an integer is given for **Z**, it is interpreted as a binary-encoded bitfield:

Weight	Bit	Flag
1	0	SCALE
2	1	DIVIDER
4	2	CHOP
8	3	FILTER

Queries always return the integer representation of the bitfield, regardless of the setting of the **TOKN** command.

### 3.4.6 Trigger commands

The trigger commands always operate on all channels.

TMOD(?) {z}	<p>Trigger Mode</p> <p>Set (query) the trigger mode {to z = (<b>LOCAL 0</b>, <b>EXTERNAL 1</b>, or <b>REMOTE 2</b>)}.</p>
TCNT(?) {j}	<p>Trigger Count</p> <p>Set (query) the number of samples per trigger {to j}. The maximum j = 65535.</p>
TREM(?) {j}	<p>Trigger Count Remaining</p> <p>Set (query) the number of samples remaining {to j}.</p> <p>TREM is used to shorten or terminate an active triggered ensemble of readings. j = 0 will terminate the ensemble. Note that TREM j can only <i>decrease</i> the remaining trigger count; if j exceeds the remaining count, it is ignored.</p>

---

**TPER(?) {k}**                      Trigger Period

Set (query) the period between samples {to *k*}, in ms.

TPER controls the period between multiple TCNT samples following an EXTERNAL or REMOTE trigger event. *k* must be an integer multiple of 10 ms, and not exceed 655350 ms (about 11 minutes).

---

**\*TRG**                                Trigger

Initiate a remote trigger.

The SIM970 must first be set to TMOD REMOTE before issuing a \*TRG command.

---

### 3.4.7 Status commands

The Status commands query and configure registers associated with status reporting of the SIM970. See Section 3.5 for the status model.

---

**\*CLS**                                Clear Status

\*CLS immediately clears the ESR, CESR, and the SIM970 status registers.

---

**\*STB? [i]**                         Status Byte

Query the Status Byte Register [bit *i*].

Execution of the \*STB? query (without the optional bit *i*) always causes the –STATUS signal to be deasserted. Note that \*STB? *i* will *not* clear –STATUS, even if bit *i* is the only bit presently causing the –STATUS signal.

\*STB? clears the TRIG bit (Section 3.5.1) in the SB register.

---

**\*SRE(?) [i,] {j}**                 Service Request Enable

Set (query) the Service Request Enable Register [bit *i*] {to *j*}.

---

**\*ESR? [i]**                         Standard Event Status

Query the Standard Event Status Register [bit *i*].

Upon execution of \*ESR?, the returned bit(s) of the ESR register are cleared.

---

**\*ESE(?) [i,] {j}**                 Standard Event Status Enable

Set (query) the Standard Event Status Enable Register [bit *i*] {to *j*}.

---

---

CESR? [ <i>i</i> ]	<p>Communication Error Status</p> <p>Query the Communication Error Status Register [bit <i>i</i>].</p> <p>Upon executing a CESR? query, the returned bit(s) of the CESR register are cleared.</p>
CESE(?) [ <i>i</i> ,] { <i>j</i> }	<p>Communication Error Status Enable</p> <p>Set (query) the Communication Error Status Enable Register [bit <i>i</i>] {to <i>j</i>}.</p>
CHSR? [ <i>i</i> ]	<p>Channel Status</p> <p>Query the Channel Status Register [bit <i>i</i>].</p> <p>Upon executing a CHSR? query, the returned bit(s) of the CHSR register are cleared.</p>
CHSE(?) [ <i>i</i> ,] { <i>j</i> }	<p>Channel Status Enable</p> <p>Set (query) the Channel Status Enable Register [bit <i>i</i>] {to <i>j</i>}.</p>
PSTA(?) { <i>z</i> }	<p>Pulse –STATUS Mode</p> <p>Set (query) the Pulse –STATUS mode {to <i>z</i> = (<b>OFF</b> 0, ON 1)}.</p> <p>When PSTA ON is set, all new service requests will only <i>pulse</i> the –STATUS signal LOW (for a minimum of 1 μs). The default behavior is to latch –STATUS LOW until a *STB? query is received.</p>
LBTN?	<p>Last Button</p> <p>Query the number of the last button pressed. The response is 1, 2, 3, or 4, based on which channel's button was last pressed. 0 is returned if no button was pressed since the last LBTN?.</p>

---

### 3.4.8 Interface commands

The Interface commands provide control over the interface between the SIM970 and the host computer.



---

*RST	<p>Reset</p> <p>Reset the SIM970 to its default configuration. The effects of *RST are a subset of what happens during power-on.</p> <p>*RST sets the following:</p> <ul style="list-style-type: none"> <li>• All four channels to Range 1, autoranging ALL.</li> <li>• The display and the front-panel buttons to ON.</li> <li>• The trigger mode to LOCAL.</li> <li>• The trigger count (TCNT) and the remaining trigger count (TREM) to 1.</li> <li>• The trigger period (TPER) to 1000 ms.</li> <li>• The token mode to OFF.</li> <li>• One LOCAL trigger is issued immediately.</li> </ul> <p>After *RST, autoranging may quickly bring the SIM970 into a Range other than Range 1.</p> <p>The reset does not attempt to clear the overload (trip) state of a channel.</p>
*IDN?	<p>Identify</p> <p>Query the device identification string.</p> <p>The identification string is formatted as:</p> <p><code>Stanford_Research_Systems,SIM970,s/n*****,ver#.###</code></p> <p>where SIM970 is the model number, ***** is a 6-digit serial number, and #.### is the firmware revision level.</p>
*TST?	<p>Self Test</p> <p>There is no internal self-test in the SIM970 after the power-on, so this query always returns 0.</p>
*OPC(?)	<p>Operation Complete</p> <p>Sets the OPC flag in the ESR register.</p> <p>The query form *OPC? writes a 1 into the output queue when complete, but does not affect the ESR register.</p>

---

---

 CONS(?) {z}

Console Mode

Set (query) the console mode {to z = (**OFF 0**, **ON 1**)}.

CONS causes each character received at the input buffer to be copied to the output queue.

---

LEXE?

Execution Error

Query the Last Execution Error code. Valid codes are:

Value	Definition
0	No execution error since last LEXE?
1	Illegal value
2	Wrong token
3	Invalid bit
16	Nothing to do
17	Illegal message
18	Wrong mode

Error 18 only occurs in response to trigger mode change requests that come while the instrument is BUSY, and to \*TRG triggers received while not in the REMOTE trigger mode.

---

LCME?

Command Error

Query the Last Command Error code. Valid codes are:

Value	Definition
0	No command error since last LCME?
1	Illegal command
2	Undefined command
3	Illegal query
4	Illegal set
5	Missing parameter(s)
6	Extra parameter(s)
7	Null parameter(s)
8	Parameter buffer overflow
10	Bad integer
11	Bad integer token
12	Bad token value
14	Unknown token

---

LDDE?	Device Error
-------	--------------

Query the Last Device-Dependent Error code. Valid codes are:

Value	Definition
0	No device error since last LDDE?
1	Cannot start
2	Hardware fault
3	Reading incomplete
4	Converter overflow
5	Converter underflow
6	Reference bad
7	Illegal mode

Errors 4 and 5 may occur during a normal power-on self-test. Error 7 is in response to a user's request for an illegal mode (Section 2.3.3).

---

TOKN(?) {z}	Token Mode
-------------	------------

Set (query) the token query mode {to z = (**OFF** 0, **ON** 1)}.

If TOKN ON is set, then queries to the SIM970 that return tokens will return a text keyword; otherwise they return a decimal integer value. Thus, the only possible responses to the TOKN? query are ON and 0.

---

TERM(?) {z}	Response Termination
-------------	----------------------

Set (query) the <term> sequence {to z = (**NONE** 0, **CR** 1, **LF** 2, **CRLF** 3, or **LFCR** 4)}.

The <term> sequence is appended to all query responses sent by the module, and is constructed of ASCII character(s) 13 (carriage return) and 10 (line feed). The token mnemonic gives the sequence of characters.

---

### 3.4.9 Serial communication commands

Note that the SIM970 does not support serial flow control.

---

BAUD(?) {k}	Baud Rate
-------------	-----------

Set (query) the baud rate {to k}.

At power-on, the baud rate defaults to 9600.

---

PARI(?) {z}	Parity
-------------	--------

Set (query) the parity {to z = (**NONE** 0, **ODD** 1, **EVEN** 2, **MARK** 3, **SPACE** 4)}.

---

### 3.5 Status Model

status registers The SIM970 status registers follow the hierarchical IEEE-488.2 format. A block diagram of the status register array is given in Figure 3.1.

There are two categories of registers in the SIM970 status model:

Event Registers : These read-only registers record the occurrence of defined events. If the event occurs, the corresponding bit is set to 1. Upon querying an event register, all set bits within it are cleared. These are sometimes known as “sticky bits,” since once set, a bit can only be cleared by reading its value. Event register names end with SR.

Enable Registers : These read/write registers define a bitwise mask for their corresponding event register. If a bit position is set in an event register while the same bit position is also set in the enable register, then the corresponding summary bit message is set. Enable register names end with SE.

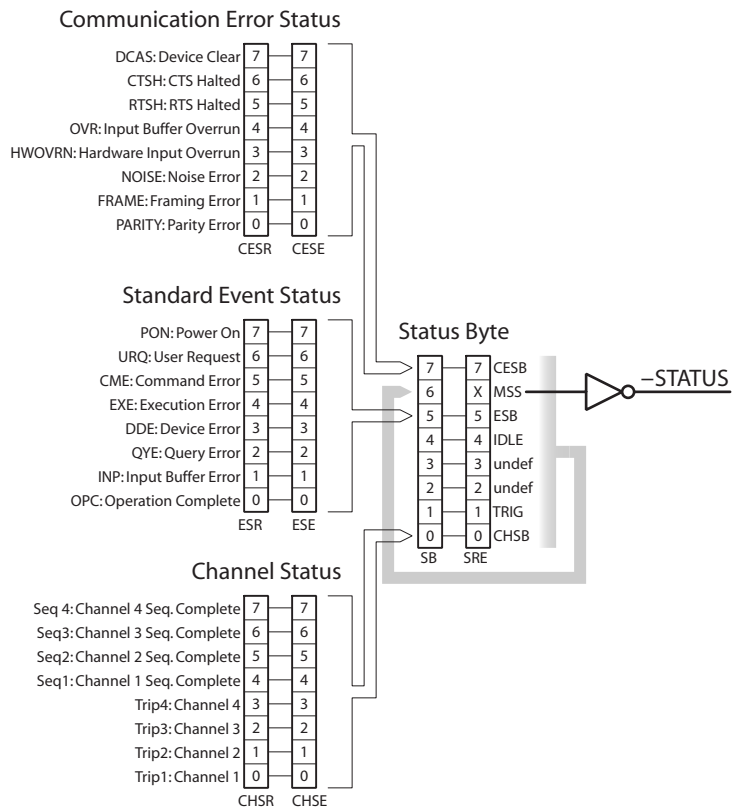

Figure 3.1: Status register model for the SIM970 Quad Digital Voltmeter.

### 3.5.1 Status Byte (SB)

The Status Byte is the top-level summary of the SIM970 status model. When masked by the Service Request Enable Register, a bit set in the Status Byte causes the  $\text{-STATUS}$  signal to be asserted on the rear-panel SIM interface connector.

Weight	Bit	Flag
1	0	CHSB
2	1	TRIG
4	2	undef (0)
8	3	undef (0)
16	4	IDLE
32	5	ESB
64	6	MSS
128	7	CESB

**CHSB :** Channel Status Summary Bit. Indicates whether one or more of the enabled flags in the Channel Status Register has become true.

**TRIG :** Trigger Status Bit. Indicates that a trigger event (either \*TRG or an external TTL LOW at the  $\text{-TRIGGER}$  input) has been received. Note that this is the only bit in the Status Byte that is cleared by \*STB?.

**IDLE :** Indicates that the input buffer is empty and the command parser is idle. Can be used to help synchronize SIM970 query responses.

**ESB :** Event Status Bit. Indicates whether one or more of the enabled events in the Standard Event Status Register is true.

**MSS :** Master Summary Status. Indicates whether one or more of the enabled status messages in the Status Byte Register is true.

**CESB :** Communication Error Summary Bit. Indicates whether one or more of the enabled flags in the Communication Error Status Register has become true.

### 3.5.2 Service Request Enable (SRE)

Each bit in the SRE corresponds one-to-one with a bit in the SB register, and acts as a bitwise AND of the SB flags to generate MSS. Bit 6 of the SRE is undefined—setting it has no effect, and reading it always returns 0. This register is set and queried with the \*SRE(?) command.

At power-on, this register is cleared.

### 3.5.3 Standard Event Status (ESR)

The Standard Event Status Register consists of 8 event flags. These event flags are all “sticky bits” that are set by the corresponding events, and cleared only by reading or with the \*CLS command. Reading a single bit (with the \*ESR? *i* query) clears only bit *i*.

Weight	Bit	Flag
1	0	OPC
2	1	INP
4	2	QYE
8	3	DDE
16	4	EXE
32	5	CME
64	6	URQ
128	7	PON

OPC : Operation Complete. Set by the \*OPC command.

INP : Input Buffer Error. Indicates data has been discarded from the input buffer.

QYE : Query Error. Indicates data in the output queue has been lost.

DDE : Device-Dependent Error. Indicates that the SIM970 had a delayed execution error, due to a request for an illegal mode, a power-on self-test failure, or a converter fault.

EXE : Execution Error. Indicates the error in a command that was successfully parsed. Out-of-range parameters are an example.

CME : Command Error. Indicates a command parser-detected error.

URQ : User Request. Indicates that a front-panel button was pressed.

PON : Power On. Indicates that an off-to-on transition has occurred.

### 3.5.4 Standard Event Status Enable (ESE)

The ESE acts as a bitwise AND with the ESR register to produce the single-bit ESB message in the Status Byte Register (SB). The register can be set and queried with the \*ESE(?) command.

At power-on, this register is cleared.

### 3.5.5 Communication Error Status (CESR)

The Communication Error Status Register consists of 8 event flags; each of the flags is set by the corresponding event, and cleared only by reading the register or with the \*CLS command. Reading a single bit (with the CESR? *i* query) clears only bit *i*.

Weight	Bit	Flag
1	0	PARITY
2	1	FRAME
4	2	NOISE
8	3	HWOVRN
16	4	OVR
32	5	RTSH
64	6	CTSH
128	7	DCAS

PARITY : Parity Error. Set by serial parity mismatch on the incoming data byte.

FRAME : Framing Error. Set when an incoming serial data byte is missing the STOP bit.

NOISE : Noise Error. Set when an incoming serial data byte does not present a steady logic level during each asynchronous bit-period window.

HWOVRN : Hardware Overrun. Set when an incoming serial data byte is lost due to internal processor latency. Causes the input buffer to be flushed, and resets the command parser.

OVR : Input Buffer Overrun. Set when the input buffer is overrun by the incoming data. Causes the input buffer to be flushed, and resets the command parser.

RTSH : Undefined for the SIM970. A command error. Indicates a parser-detected error.

CTSH : Undefined for the SIM970.

DCAS : Device Clear. Indicates that the SIM970 received the Device Clear signal (an RS-232 <break>). Clears the input buffer and the output queue, and resets the command parser.

### 3.5.6 Communication Error Status Enable (CESE)

The CESE acts as a bitwise AND with the CESR register to produce the single-bit CESB message in the Status Byte Register (SB). The register can be set and queried with the CESE(?) command.

At power-on, this register is cleared.

### 3.5.7 Channel Status (CHSR)

The Channel Status Register consists of 8 event flags; each of the flags is set by the corresponding event, and cleared only by reading the register or with the \*CLS command. Reading a single bit (with the CHSR? *i* query) clears only bit *i*.

Weight	Bit	Flag
1	0	Trip1
2	1	Trip2
4	2	Trip3
8	3	Trip4
16	4	Seq1
32	5	Seq2
64	6	Seq3
128	7	Seq4

**Trip $n$**  : Input Overload. Indicates that Channel  $n$  had an input over-voltage protection trip.

**Seq $n$**  : Reading Sequence Complete. Indicates that a triggered ensemble of reading sequences for Channel  $n$  has completed. This bit is set for all trigger modes, including LOCAL; in the latter case, the ensemble consists of a single autocalibration sequence.

While reading this register (with the CHSR? query) will clear all Trip $n$  bit(s) that are set, it will *not* reset the overvoltage protection circuit. To do that, the user must issue the TRIP command. As long as Channel  $n$  remains tripped off, the Trip $n$  bit will be continuously reasserted.

### 3.5.8 Channel Status Enable (CHSE)

The CHSE acts as a bitwise AND with the CHSR register to produce the single-bit CHSB message in the Status Byte Register (SB). The register can be set and queried with the CHSE(?) command.

At power-on, this register is cleared.



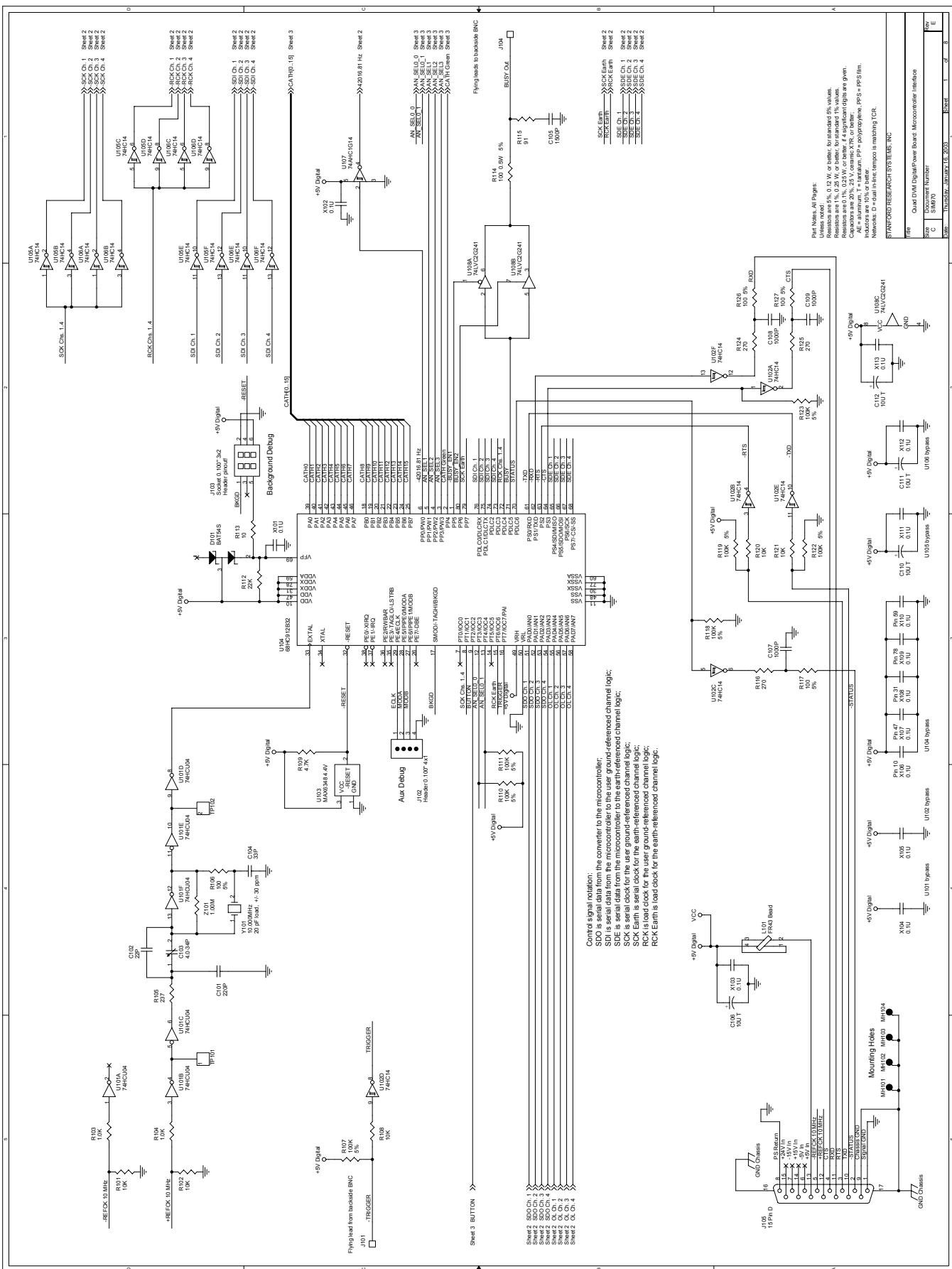

CONTR. signal notation:  
 SDO is serial data from the converter to the microcontroller.  
 SDI is serial data from the microcontroller to the user ground-referenced channel logic.  
 SDE is serial data from the user ground-referenced channel logic.  
 SCK is serial clock for the user ground-referenced channel logic.  
 SCK is serial clock for the earth-referenced channel logic.  
 RCK is load clock for the user ground-referenced channel logic.  
 RCK is load clock for the earth-referenced channel logic.

Part Notes: All Pagers:  
 Unless noted:  
 Resistors are 1%, 0.1W, or better, for standard 5% values.  
 Resistors are 1%, 0.25W, or better, for standard 1% values.  
 Inductors are 1% or better.  
 Capacitors are 5% or better.  
 AE = aluminum, T = tantalum, PP = polypropylene, PPS = PPS film.  
 Dimensions: D = dimension, unless specified in matching TCN.

STANFORD RESEARCH SYSTEMS, INC.

Rev	Quad DVM Digital Power Board - Microcontroller Interface
Doc	Document Number
Part	16070
Date	January 11, 2001
Sheet	1 of 8

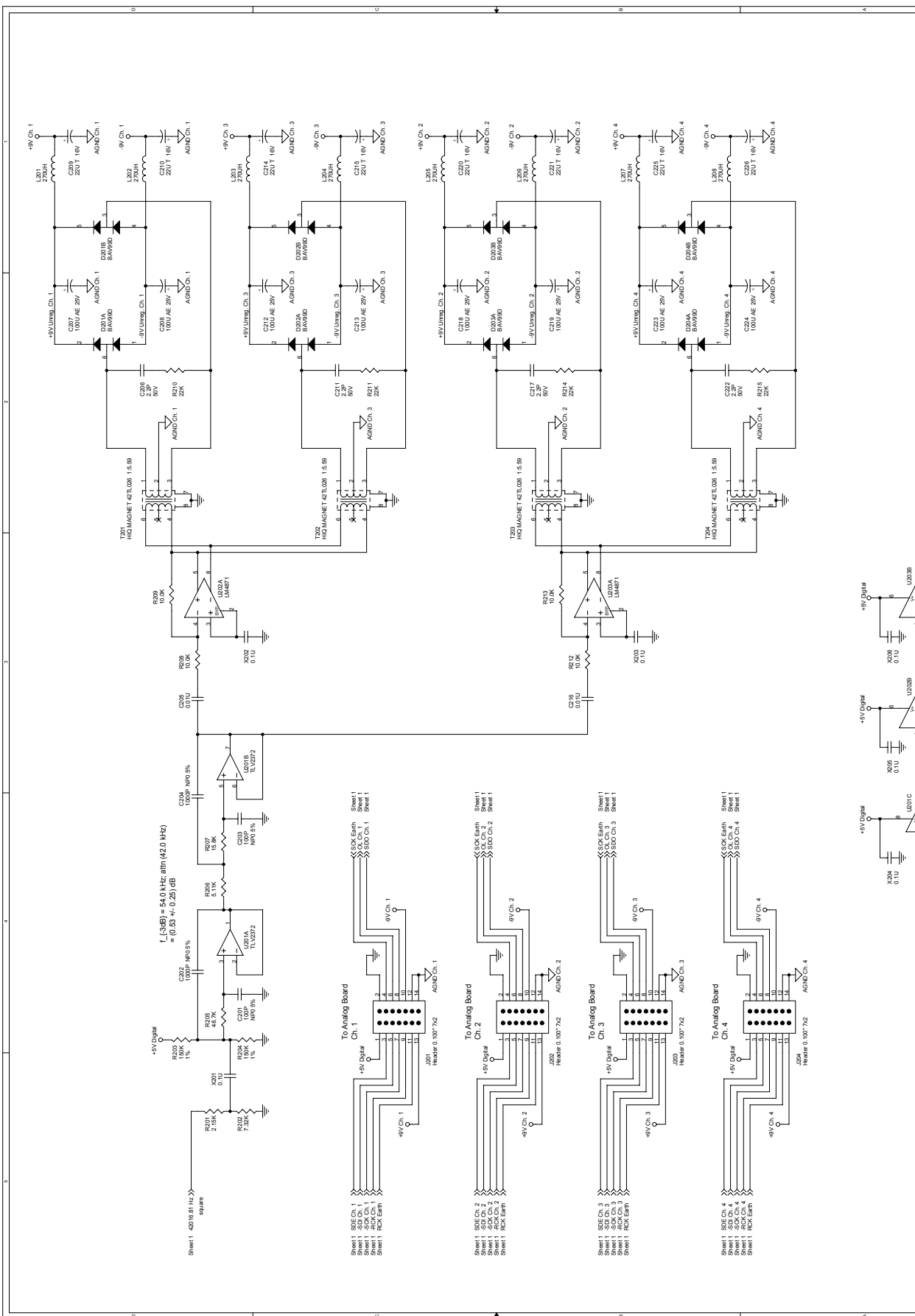

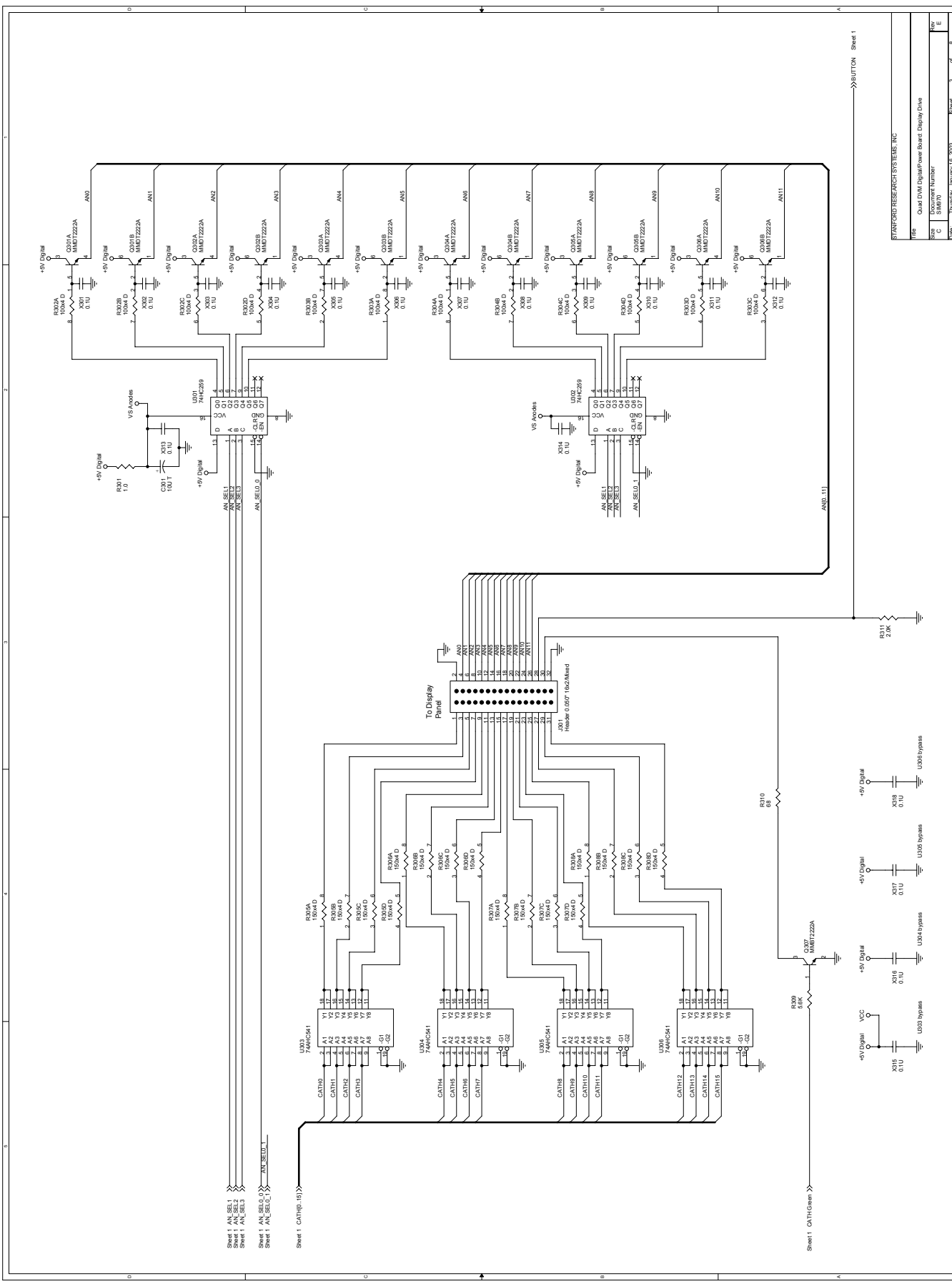

Sheet 1

Sheet 1

Sheet 1

Sheet 1

Sheet 1

Sheet 1

Sheet 1

Sheet 1

Sheet 1

Sheet 1

Sheet 1

Sheet 1

Sheet 1

Sheet 1

Sheet 1

Sheet 1

Sheet 1

Sheet 1

Sheet 1

Sheet 1

Sheet 1

Sheet 1

Sheet 1

Sheet 1

Sheet 1

Sheet 1

Sheet 1

Sheet 1

Sheet 1

Sheet 1

Sheet 1

Sheet 1

Sheet 1

Sheet 1

Sheet 1

Sheet 1

Sheet 1

Sheet 1

Sheet 1

Sheet 1

Sheet 1

Sheet 1

Sheet 1

Sheet 1

Sheet 1

Sheet 1

Sheet 1

Sheet 1

Sheet 1

Sheet 1

Sheet 1

Sheet 1

Sheet 1

Sheet 1

Sheet 1

Sheet 1

Sheet 1

Sheet 1

Sheet 1

Sheet 1

Sheet 1

Sheet 1

Sheet 1

Sheet 1

Sheet 1

Sheet 1

Sheet 1

Sheet 1

Sheet 1

Sheet 1

Sheet 1

Sheet 1

Sheet 1

Sheet 1

Sheet 1

Sheet 1

Sheet 1

Sheet 1

Sheet 1

Sheet 1

Sheet 1

Sheet 1

Sheet 1

Sheet 1

Sheet 1

Sheet 1

Sheet 1

Sheet 1

Sheet 1

Sheet 1

Sheet 1

Sheet 1

Sheet 1

Sheet 1

Sheet 1

Sheet 1

Sheet 1

Sheet 1

Sheet 1

Sheet 1

Sheet 1

Sheet 1

Sheet 1

Sheet 1

Sheet 1

Sheet 1

Sheet 1

Sheet 1

Sheet 1

Sheet 1

Sheet 1

Sheet 1

Sheet 1

Sheet 1

Sheet 1

Sheet 1

Sheet 1

Sheet 1

Sheet 1

Sheet 1

Sheet 1

Sheet 1

Sheet 1

Sheet 1

Sheet 1

Sheet 1

Sheet 1

Sheet 1

Sheet 1

Sheet 1

Sheet 1

Sheet 1

Sheet 1

Sheet 1

Sheet 1

Sheet 1

Sheet 1

Sheet 1

Sheet 1

Sheet 1

Sheet 1

Sheet 1

Sheet 1

Sheet 1

Sheet 1

Sheet 1

Sheet 1

Sheet 1

Sheet 1

Sheet 1

Sheet 1

Sheet 1

Sheet 1

Sheet 1

Sheet 1

Sheet 1

Sheet 1

Sheet 1

Sheet 1

Sheet 1

Sheet 1

Sheet 1

Sheet 1

Sheet 1

Sheet 1

Sheet 1

Sheet 1

Sheet 1

Sheet 1

Sheet 1

Sheet 1

Sheet 1

Sheet 1

Sheet 1

Sheet 1

Sheet 1

Sheet 1

Sheet 1

Sheet 1

Sheet 1

Sheet 1

Sheet 1

Sheet 1

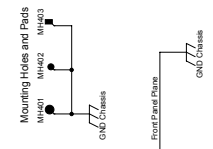
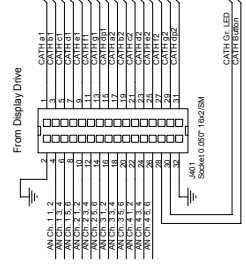
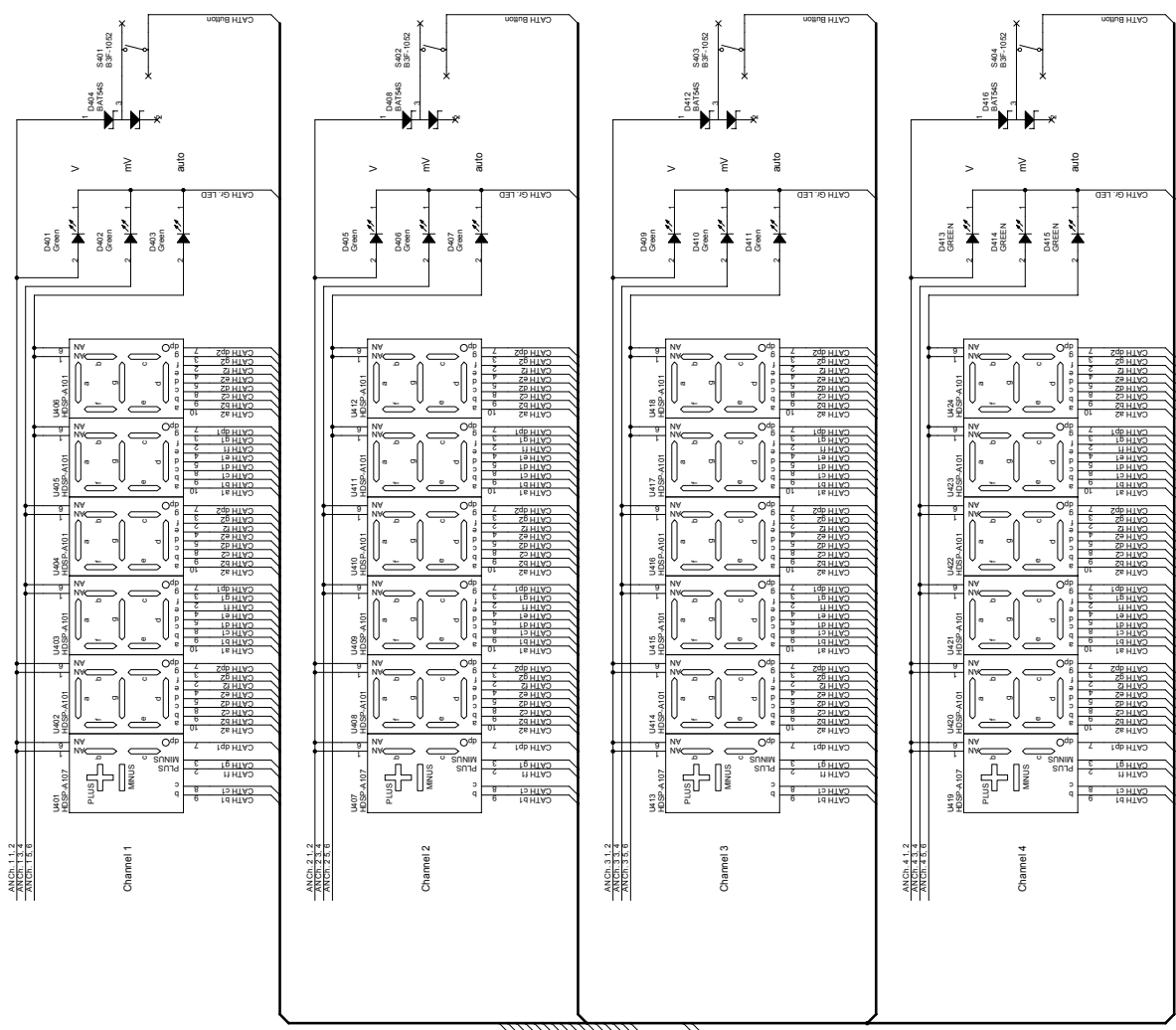

Signal-Referenced Circuitry:

Mounting Holes  
M4501 M4502

Signal Under Test:  
Twisted shielded pair from  
front panel connector  
BNC-Ch. Ods

Input passive filtering

Input chop

Input buffer

Level translator

Input active filtering

Overload detection

Input impedance crossover servo

Proportional amp

Integral amp

Differential amp

42 kHz notch filter

Inverse Chebyshev

Error amplifier

A->D converter

Power connections

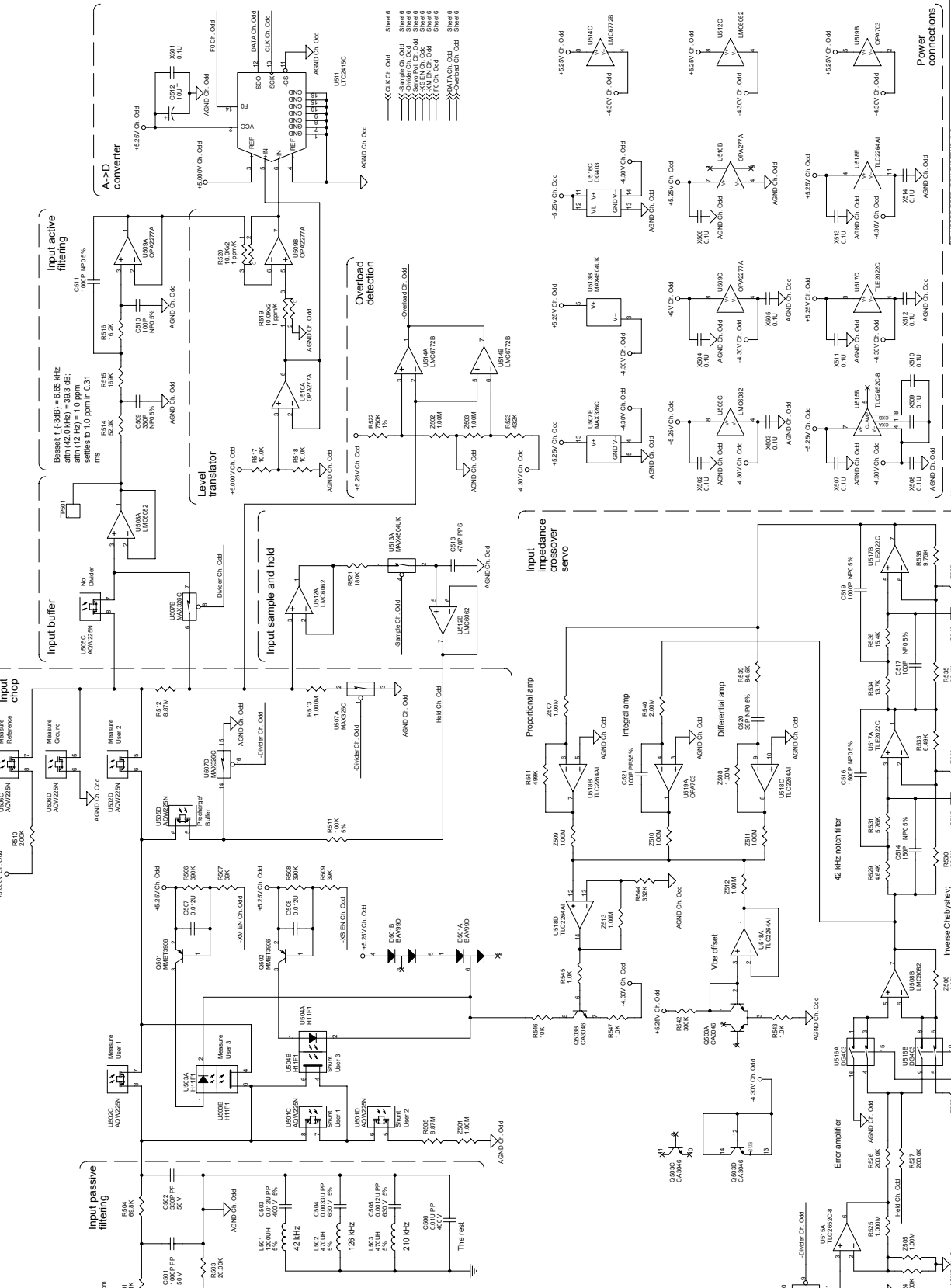

Notes:  
(1) The following components share parts across Pages 5 and 6:  
U901, U902, U505, U506  
(2) The four channels on the two Analog boards are absolutely identical.

Signal-Referenced Circuitry:

Earth-Referenced Circuitry:

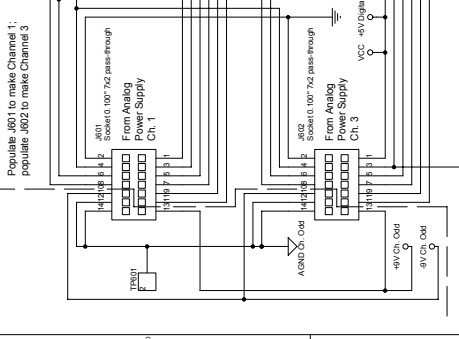

Analog switch/ opto-EI/FO control

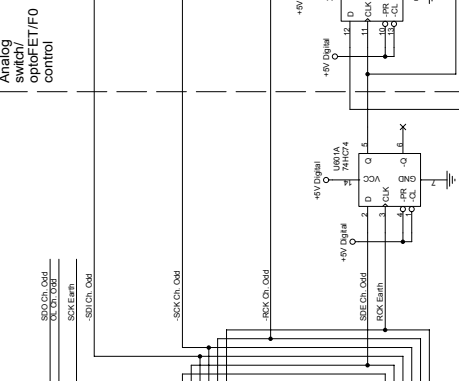

Signal-Referenced Circuitry:

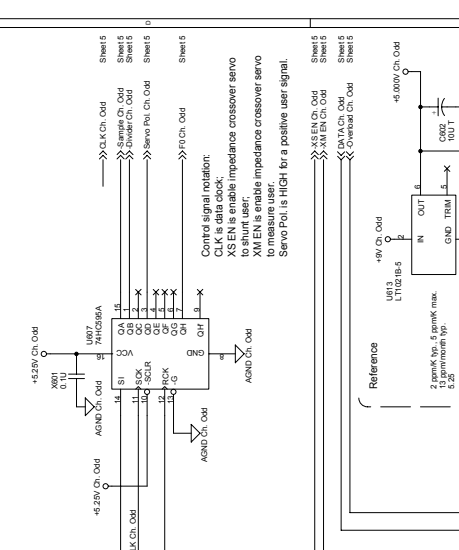

Output interface

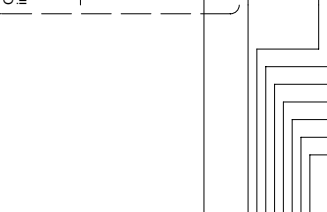

PhotomOS control

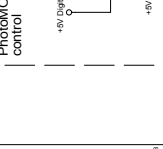

Reference and power

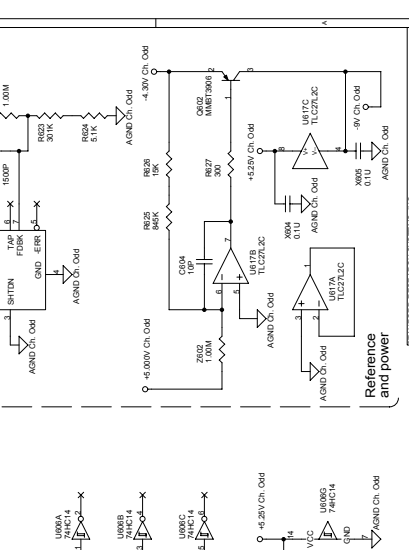
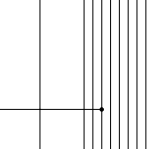

Notes:

- (1) The following components share parts across Pages 5 and 6:  
UR01, UR02, UR05, UR06
- (2) The four channels on the two Analog boards are absolutely identical.

Signal-Referenced Circuitry:

Mounting Holes  
M101 M102

Twisted shielded pair from  
front panel connector  
BNC-Ch. Even

Shield  
GND chassis

Shield  
GND chassis

Shield  
GND chassis

Shield  
GND chassis

Shield  
GND chassis

Shield  
GND chassis

Shield  
GND chassis

Shield  
GND chassis

Shield  
GND chassis

Shield  
GND chassis

Shield  
GND chassis

Shield  
GND chassis

Shield  
GND chassis

Shield  
GND chassis

Shield  
GND chassis

Shield  
GND chassis

Shield  
GND chassis

Shield  
GND chassis

Shield  
GND chassis

Shield  
GND chassis

Shield  
GND chassis

Shield  
GND chassis

Shield  
GND chassis

Shield  
GND chassis

Shield  
GND chassis

Shield  
GND chassis

Shield  
GND chassis

Shield  
GND chassis

Shield  
GND chassis

Shield  
GND chassis

Shield  
GND chassis

Shield  
GND chassis

Shield  
GND chassis

Shield  
GND chassis

Shield  
GND chassis

Shield  
GND chassis

Shield  
GND chassis

Shield  
GND chassis

Shield  
GND chassis

Shield  
GND chassis

Shield  
GND chassis

Shield  
GND chassis

Shield  
GND chassis

Shield  
GND chassis

Shield  
GND chassis

Shield  
GND chassis

Shield  
GND chassis

Shield  
GND chassis

Shield  
GND chassis

Shield  
GND chassis

Shield  
GND chassis

Shield  
GND chassis

Shield  
GND chassis

Shield  
GND chassis

Shield  
GND chassis

Shield  
GND chassis

Shield  
GND chassis

Shield  
GND chassis

Shield  
GND chassis

Input passive filtering

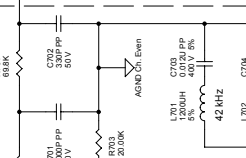

Signal Under Test:  
Twisted shielded pair from  
front panel connector  
BNC-Ch. Even

Shield  
GND chassis

Shield  
GND chassis

Shield  
GND chassis

Shield  
GND chassis

Shield  
GND chassis

Shield  
GND chassis

Shield  
GND chassis

Shield  
GND chassis

Shield  
GND chassis

Shield  
GND chassis

Shield  
GND chassis

Input chop

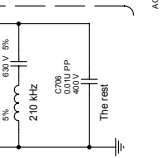

Measures  
Impedance

Measures  
Ground

Measures  
User 1

Measures  
User 2

Measures  
User 3

Measures  
User 4

Measures  
User 5

Measures  
User 6

Measures  
User 7

Measures  
User 8

Measures  
User 9

Measures  
User 10

Level translator



Measures  
Impedance

Measures  
Ground

Measures  
User 1

Measures  
User 2

Measures  
User 3

Measures  
User 4

Measures  
User 5

Measures  
User 6

Measures  
User 7

Measures  
User 8

Measures  
User 9

Measures  
User 10

Input active filtering

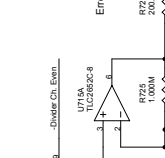

Measures  
Impedance

Measures  
Ground

Measures  
User 1

Measures  
User 2

Measures  
User 3

Measures  
User 4

Measures  
User 5

Measures  
User 6

Measures  
User 7

Measures  
User 8

Measures  
User 9

Measures  
User 10

Input buffer

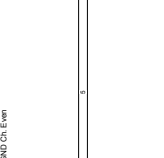

Measures  
Impedance

Measures  
Ground

</

