

Laser Shutter Systems

SR470 Series — Laser shutters and controllers



SR470 Series Shutter Systems

- Ultra-low vibration shutter head
- True mechanical laser beam blocking
- >10 M cycle lifetime
- Microprocessor controlled timing
- DC to 100 Hz
- Easy to align 3 mm aperture
- GPIB, RS-232 and Ethernet

- SR470 Controller ... \$1595 (U.S. list)
- SR474 Controller ... \$1595 (U.S. list)
- SR475 Shutter Head ... \$750 (U.S. list)

Introducing two new optical shutter systems from SRS — the SR470 Laser Shutter Controller and SR474 Four-Channel Laser Shutter Driver. These shutter systems are designed specifically to minimize vibration on your optical table.

They are built around a unique shutter head design, supported by one of two available controller models. The SR470 provides timing signals to a single shutter head, while the multi-channel SR474 drives up to four shutter heads, and is controlled by external timing signals.

The Shutter Head

Unlike conventional solenoid based shutters, the SR475 shutter head contains a closed-loop DSP control system that precisely guides the shutter blade between open and closed positions, never encountering physical stops. Vibration and mechanical noise are kept to a minimum, leaving your optical table disturbance-free.

The shutter blade is mounted between sapphire jewel bearings that minimize friction and result in a head lifetime in excess



The SR475's unique beryllium-copper shutter blade driven with rare earth magnets

of 10 M cycles — orders of magnitude more than is typically found in shutter heads.

The 3 mm clear aperture is designed for easy alignment and is large enough to be used with common light sources. Typical rise and fall times are under 500 μ s, and repetition rates from DC to 100 Hz can be used. Unlike other shutters, the SRS shutter is not duty cycle limited — you can run any duty cycle you choose.

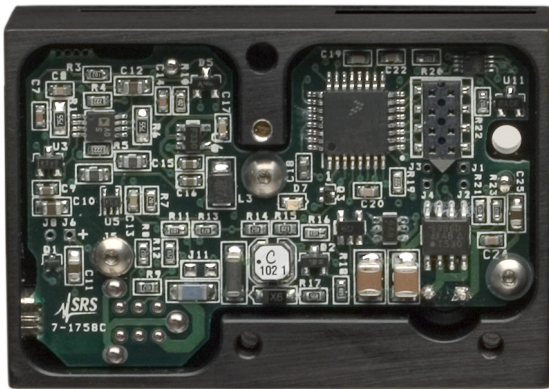

SR475 Shutter Head with cover removed, revealing control system electronics

SR470 Controller

The SR470 Shutter Controller allows you to generate timing signals for the shutter head. You have complete control of the exposure time, which can be set between 4 ms and 10,000 s with 0.1 ms resolution. Pre- and post-exposure delays can also be configured. A bright green 8-digit LED display shows the current parameter in seconds or hertz, and timing is accurate to 100 ppm.

A variety of trigger modes are provided — internal, external, front panel, and continuous — giving you the flexibility to handle just about any application. Triggered bursts from milliseconds to months can also be generated, placing the SR470 in a class of its own.



SR470 rear panel

In addition to triggered sequences, the SR470 can also act as a driver to actuate the shutter head from your own timing signals. You can also manually control the shutter from the front panel.

Remote operation is supported with GPIB, RS-232 and Ethernet computer interfaces. All instrument functions can be controlled and read over any of the interfaces. Up to nine complete instrument configurations can be saved in non-volatile RAM and recalled at any time. Shutter faults are automatically detected and reported with audible and electronic (TTL) alarms.

SR474 Four-Channel Driver

The SR474 Four-Channel Driver interfaces with up to four shutter heads. Rear-panel TTL level inputs are provided for your external timing signals. Each of the four channels can be set for normally open or normally closed operation.

Each channel has a front-panel *State* button which allows you to manually change the shutter state. The channel *Source* buttons set each channel to manual, external TTL or remote state control. Each channel also has an *Align* button that drives its shutter head at a 1 Hz rate making laser alignment simple. The Global Control section of the front-panel allow you to set or reset all channels to their “normal” states.

As with the SR470, remote operation is supported with GPIB, RS-232 and Ethernet computer interfaces. All instrument functions can be controlled and read over any of the interfaces. Shutter faults are automatically detected and result in audible, visible and electronic alarms.

Performance and Reliability

The SR470 and SR470 Laser Shutter systems from SRS offer performance and reliability not found in other systems. For more details call us at 408-744-9040.

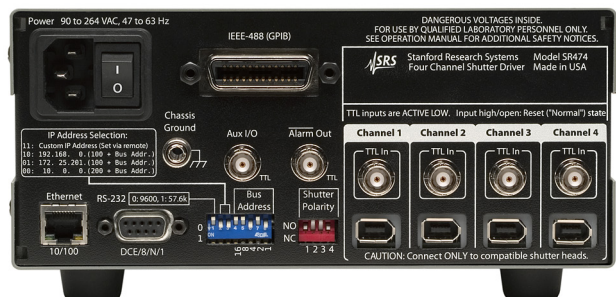

SR474 rear panel

SR475 Laser Shutter Head

Mechanical

Shutter blade	BeCu alloy, black oxide finish
Clear aperture	0.120 in. min. diameter
Repetition rate	100 Hz
Exposure rise/fall time	500 μ s typ., in full-speed
Min. exposure time	5 ms
Insertion delay jitter	10 μ s rms typ. (measured at 10 Hz rep rate)
Bearing	Sapphire jewel bearing
Blade position	Closed-loop (PID) controlled. Can be operated as NO or NC.
Opening/closing bounce	None allowed
Operating temperature	0°C to 35°C
Mounting	Any orientation

General

Max. cable length	3 m
Weight	1 lbs.
Dimensions	2.25" \times 1.6" \times 1.0" (WHD)
Power	4.5 VDC @ 250 mA 12 VDC @ 1.25 A

SR470 Controller

Timing

Resolution	100 μ s (8-digit display)
Accuracy	100 ppm
Pre-exposure delay	0 to 10,000 s
Exposure time	4 ms to 10,000 s (shutter limited)
Post-exposure delay	4 ms to 10,000 s (shutter limited)
Repetition rate	Shutter limited
Initial state	Normally open or closed (user defined)
Shutter type	SR470 Series Laser Shutters

Triggering

Modes	Internal, external TTL, external level, and front-panel, continuous
Triggered burst	1 to 99,999,999 timing cycles

System Fault and Alarms

Alarm types	Fault LED indicator, audible alarm and rear-panel TTL output. System automatically detects shutter fault.
-------------	---

Display

Type	7-segment LED, 8-digit
Display blanking	Front panel LEDs can be disabled.

General

Interfaces	GPIB, RS-232 and Ethernet. All instrument functions are controllable over the interfaces.
Shutter alignment Save/recall	<i>Align</i> button chops shutter at 1 Hz Nine sets of instrument settings can be saved and recalled.
Auxiliary I/O ports	Rear-panel Aux I/O 1 & Aux I/O 2. TTL level, multi-purpose ports.
Control input	Context sensitive TTL input. Triggers on falling edge. TTL-Hi resets to Normal state. TTL-Lo sets to Normal state.
Sync out	Rear-panel TTL level output.
Power	40 W, 90 to 264 VAC, 47 to 63 Hz
Dimensions	7.95" \times 3.37" \times 10.25" (WHL)
Weight	7 lbs.
Warranty	One year parts and labor on defects in materials and workmanship.

SR474 Four-Channel Driver

Operation

Shutter type	SR470 Series Laser Shutters
Shutter state	Shutter state can be controlled manually from front-panel or from external TTL timing signals.
Channel enable	Front-panel <i>Enable</i> buttons enable or disable each channel.
Global control	Sets or resets all channels to their "Normal" states.
Shutter alignment	Front-panel <i>Align</i> buttons cause selected channels to change state at a 1 Hz rate for easy laser alignment.

Triggering

Modes	Front-panel <i>Source</i> button selects external TTL, manual or remote (computer interface) state control.
-------	---

System Fault and Alarms

Alarm types	Fault LED indicators, audible alarm and rear-panel TTL output. System automatically detects shutter fault.
-------------	--

General

Display blanking	Front panel LEDs can be disabled.
Interfaces	GPIB, RS-232 and Ethernet. All instrument functions are controllable over the interfaces.

Auxiliary I/O port Shutter polarity	Rear-panel Aux I/O, TTL level “Normally Open” and “Normally Closed” states for each channel are set on rear-panel DIP switch.
Power	75 W, 90 to 264 VAC, 47 to 63 Hz
Dimensions	7.95" × 3.37" × 10.25" (WHL)
Weight	7 lbs.
Warranty	One year parts and labor on defects in materials and workmanship (SR475 and SR476 shutter heads are warranted for 90 days)

About the Shutter Heads

Unlike conventional designs, the SR475 Shutter Head can be mounted on your optical table in any orientation. This gives you complete flexibility to route the mating cable out of the way of your experiment.

The aperture is positioned very close to the chassis edge, making the SR475 ideal for chopping one of two parallel beams separated by less than a centimeter. It also allows you to operate your lasers very close to the plane of your optical table top.

The small size of the shutter heads make them ideal in tight quarters, and with a precision guided blade, shutter vibration is essentially eliminated.

Ordering Information

SR470	Shutter controller	\$1595
SR474	4-ch. shutter driver	\$1595
O470RMS	Single rack mount kit for SR47X	\$100
O470RMD	Double rack mount kit for SR47X	\$100
SR475	Shutter head (100 Hz)	\$750

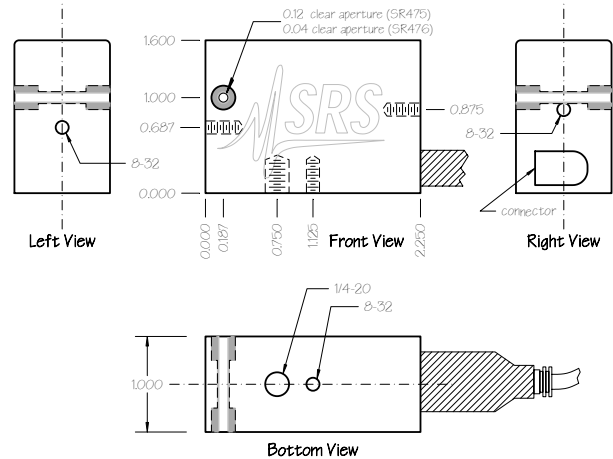

(All dimensions in inches)