

REVISIONS			
REV	DESCRIPTION	DATE	APPROVED
A	REDESIGNED FOR UNIVERSAL APPLICATION	12/17/02	GAW

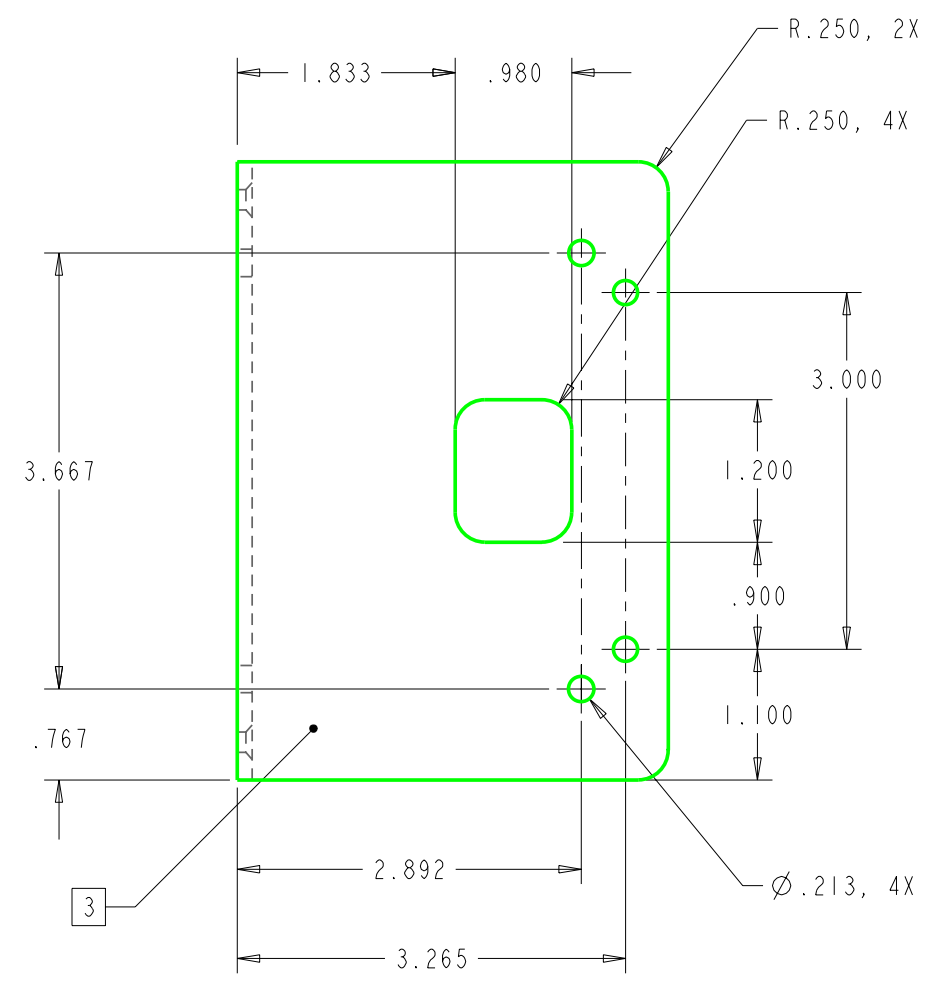
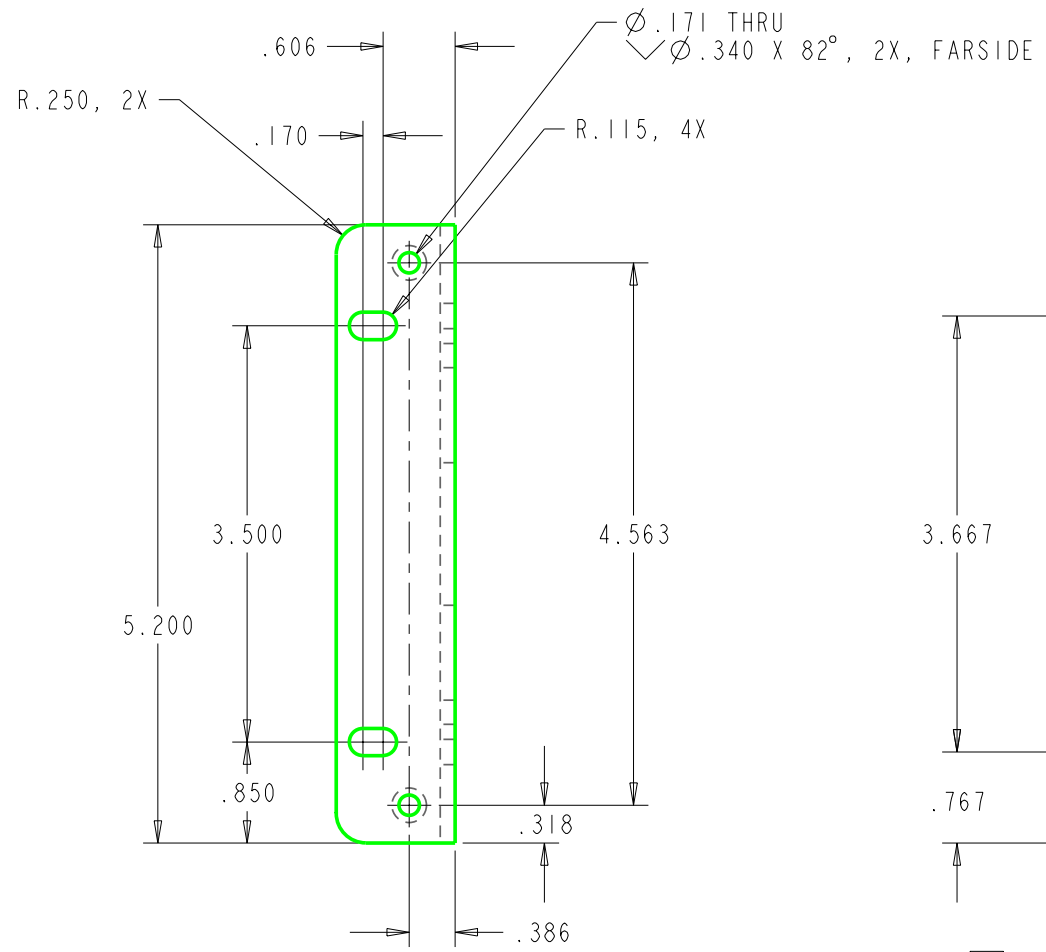
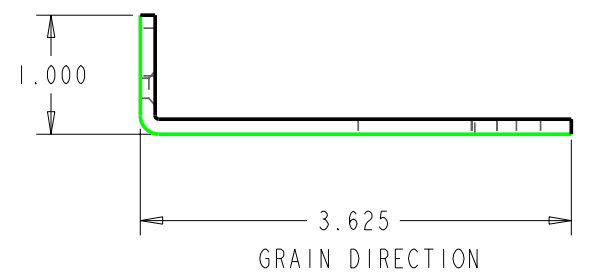

NOTES: UNLESS OTHERWISE SPECIFIED

- 1 MATERIAL: 5052-H32 ALUMINUM ALLOY, .125 THICK
- 2 FINISH: ANODIZE BLACK.
- 3 PART MARKING: VENDOR ID, MONTH/YEAR, OF MANUFACTURE, PART NUMBER, AND CURRENT REVISION LEVEL USING METAL AND/OR RUBBER STAMP APPROXIMATELY WHERE SHOWN.
- 4. REMOVE ALL BURRS AND SHARP EDGES.
- 5. BEND RADIUS SHALL BE .03 MAX.

MATERIAL	UNLESS OTHERWISE SPECIFIED, DIMENSIONS ARE IN INCHES.	SRS STANFORD RESEARCH SYSTEMS, INC. 1290-D Reamwood Avenue, Sunnyvale CA 94089	
FINISH	TOLERANCES: .X ± .XX ± .XXX ± .010 ANGLE ±	DRAWING TITLE: BRACKET, 5 1/4 RACKMOUNT, UNIVERSAL	
DO NOT SCALE DRAWING	ENG BY/DATE G. WATERS	SIZE C	PRO/E FILENAME: SRS PART NO. 7-00515-720
NEXT ASSY	DWN BY/DATE G. WATERS	SCALE: 1.00	REV A
USED ON	17-Dec-02	SHEET: 1 OF 1	